

A- Separate Zarge

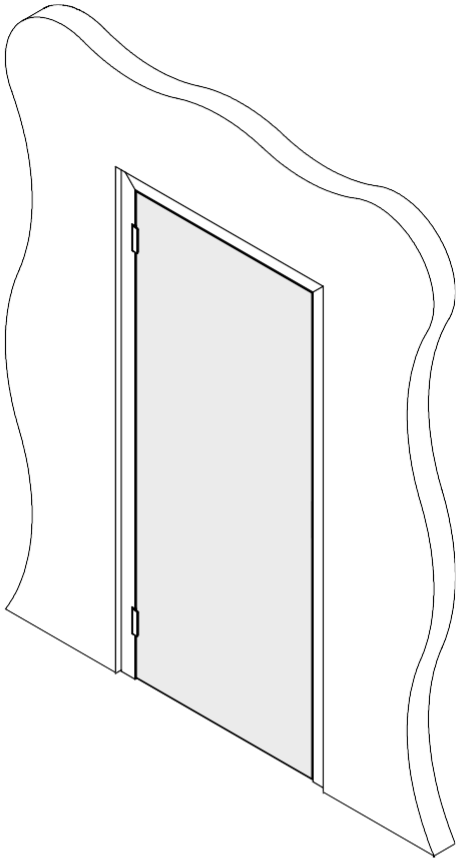

B - Zarge mit Ganzglaswand

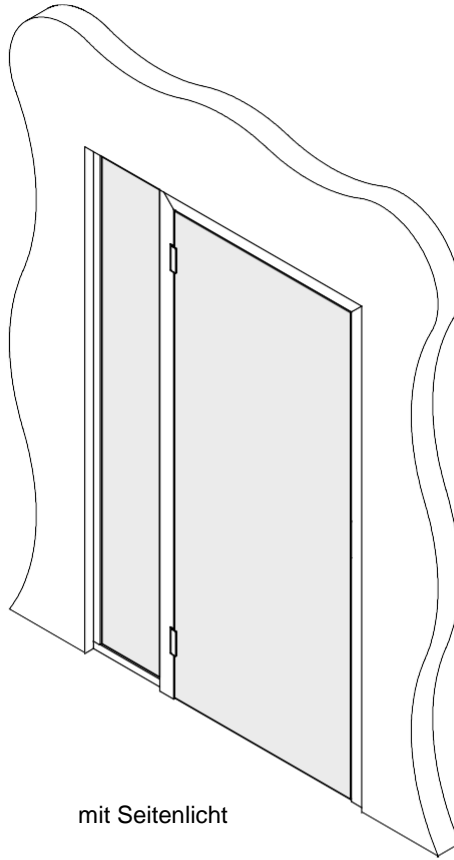

mit Seitenlicht

mit zwei
Seitenlichtern

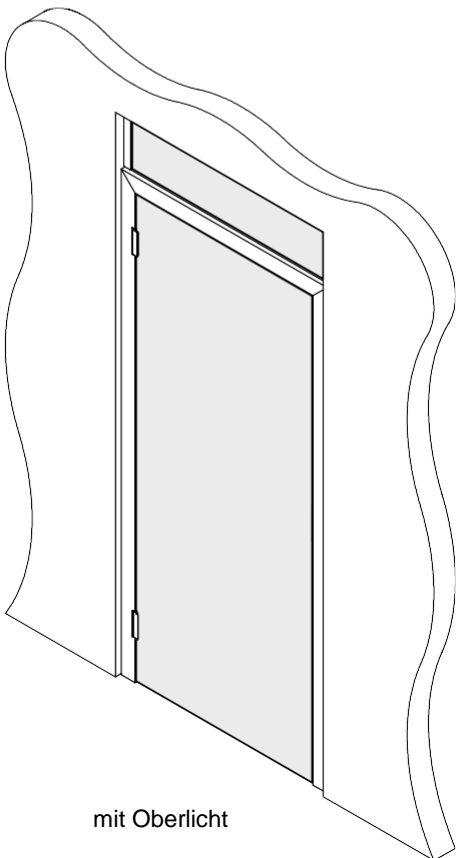



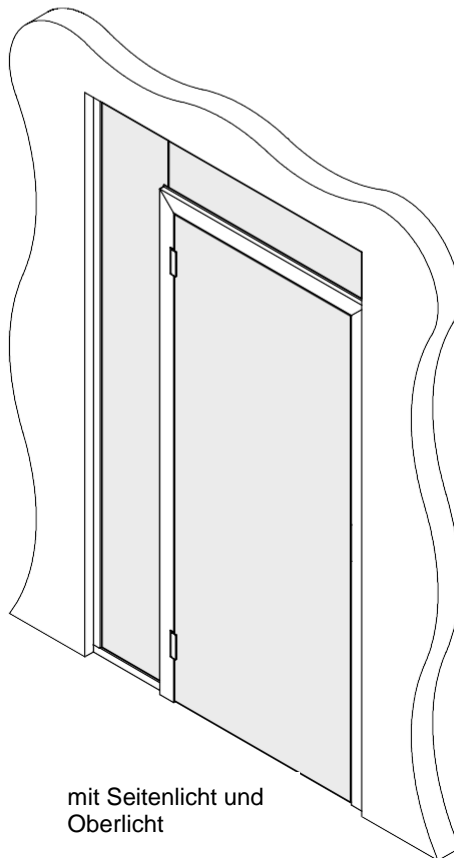



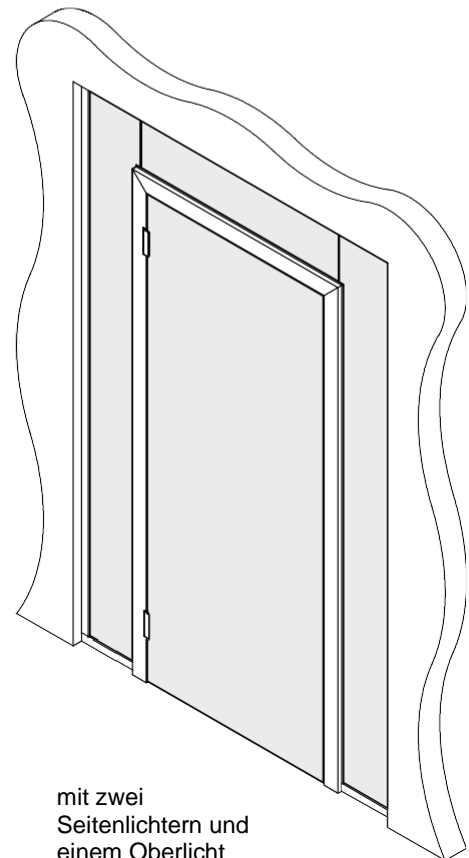



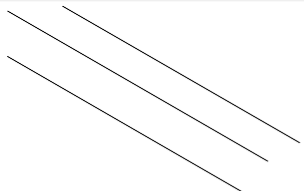

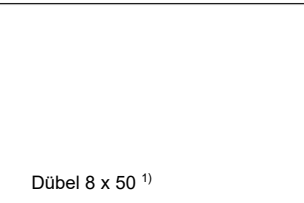
mit Oberlicht

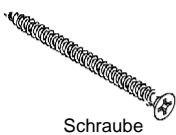

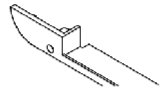
mit Seitenlicht und
Oberlicht

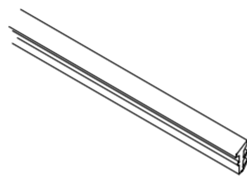
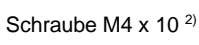
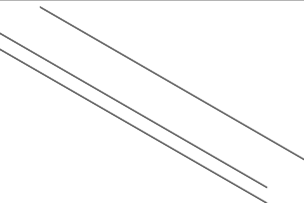
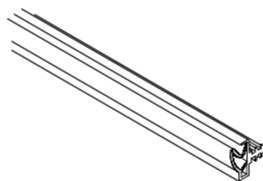
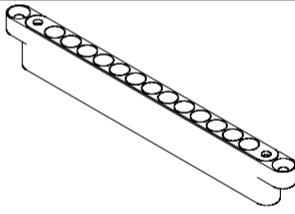
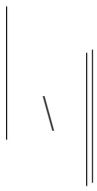
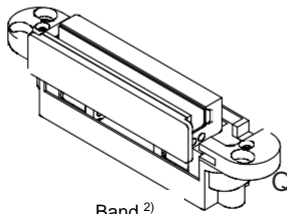

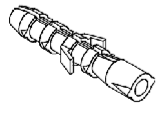
mit zwei
Seitenlichtern und
einem Oberlicht

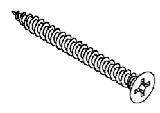
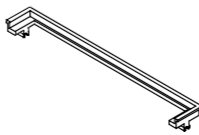
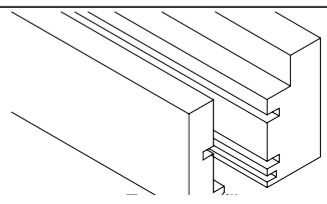
| | A | B | | A | B | | A | B |
|---|---|---|---|---|---|--|---|---|
|  Montagelatte 17 x 21 ¹⁾ | | |  Stift 6 x 30 ³⁾ | | |  Bandabdeckungen ²⁾ | | |
|  Dübel 8 x 50 ¹⁾ | | |  Schraube 4,1 x 19 | | |  Schraube M4 x 10 ²⁾ | | |
|  Schraube 4 x 60 ¹⁾ | | |  Schraube 3,5 x 25 | | |  Bandfalzabdeckung ²⁾ | | |
|  Exzenter | | |  Dichtung Ganzglas ⁴⁾ | | |  Schraube M4 x 10 ²⁾ | | |
|  eingelgte Feder 5 x 16 | | |  Zargendichtung ²⁾ | | |  Magnet | | |
|  Verankerungswinkel 20 x 45 x 2 | | |  Band ²⁾ | | |  Schraube 4,5 x 40 ²⁾ | | |
|  Dübel 8 x 46 | ✓ | ✓ |  Schraube 4,5 x 30 ²⁾ | ✓ | ✓ | | | |
|  Schraube 4,5 x 50 | ✓ | ✓ |  Bandstirnabdeckung ²⁾ | ✓ | ✓ |  Zargenprofile | ✓ | ✓ |

¹⁾ - wird bei der Verankerung der Zarge an der Wand verwendet (wird nicht zur Verankerung der Zarge am Glas verwendet)

²⁾ - wird nicht für die Durchgangszarge verwendet
 wird für die Eckverbindung der Zarge OBTUS verwendet

⁴⁾ - wird in Kombination mit Seitenlicht oder Oberlicht (Variante B) verwendet

Aufschlüsselung der Komponenten
Stumpe Rahmenseite für Ganzglastüren

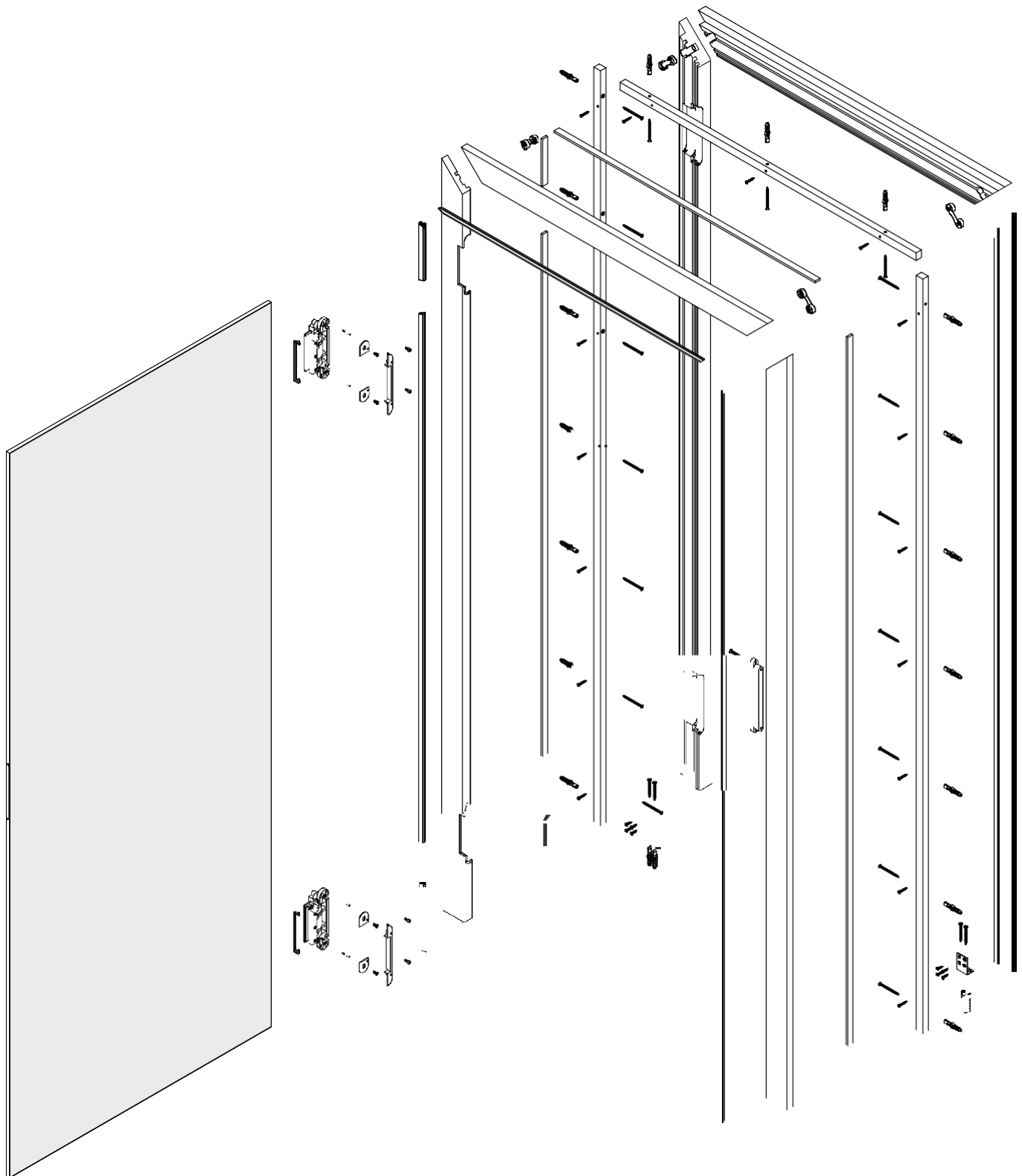

Wir empfehlen Ihnen, die Montageanleitung vor Beginn der Montage sorgfältig zu lesen oder die Montage von speziell geschultem Personal durchführen zu lassen!

1.

Anbringen vertikaler Montagelatten zur Verankerung der Zarge an der Wand -A, B

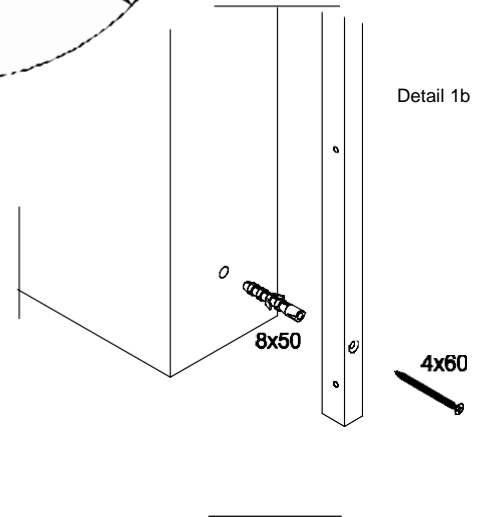
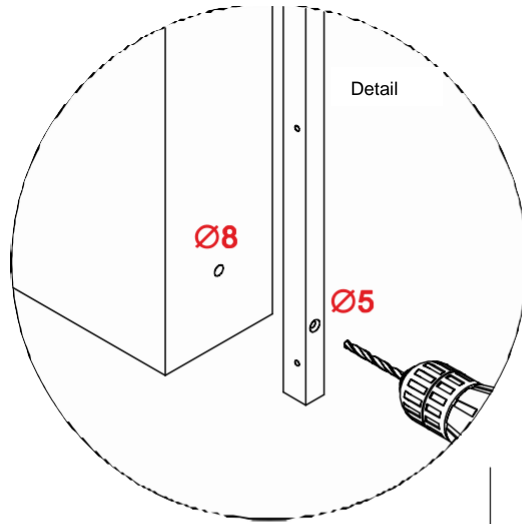
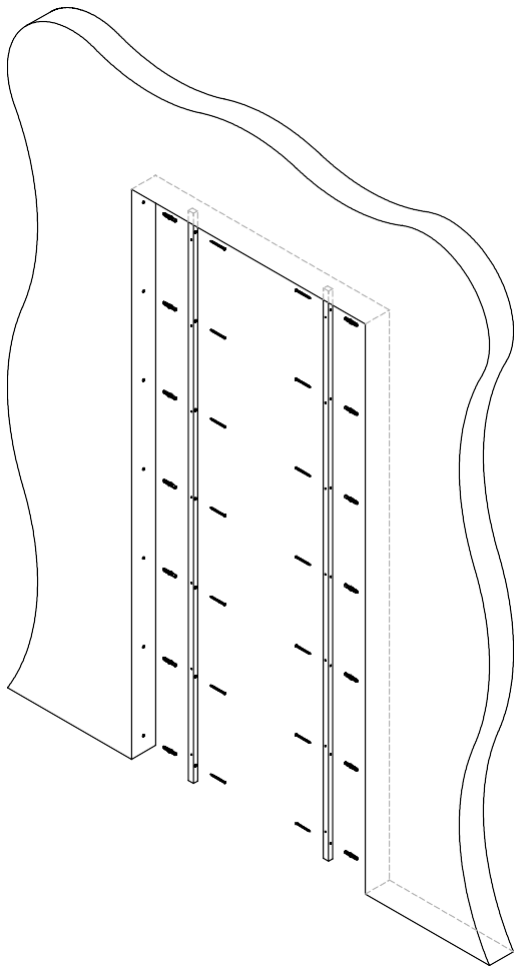

2.

Anbringen der horizontalen Montagelatte zur Verankerung der Zarge an der Wand -A, B

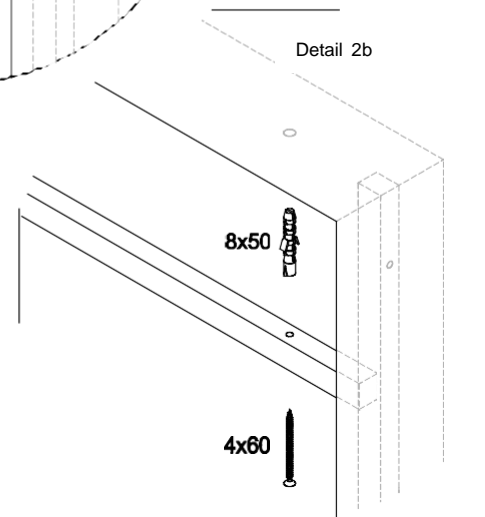
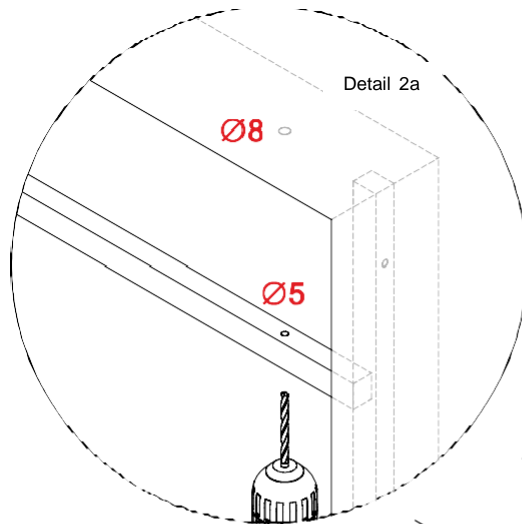
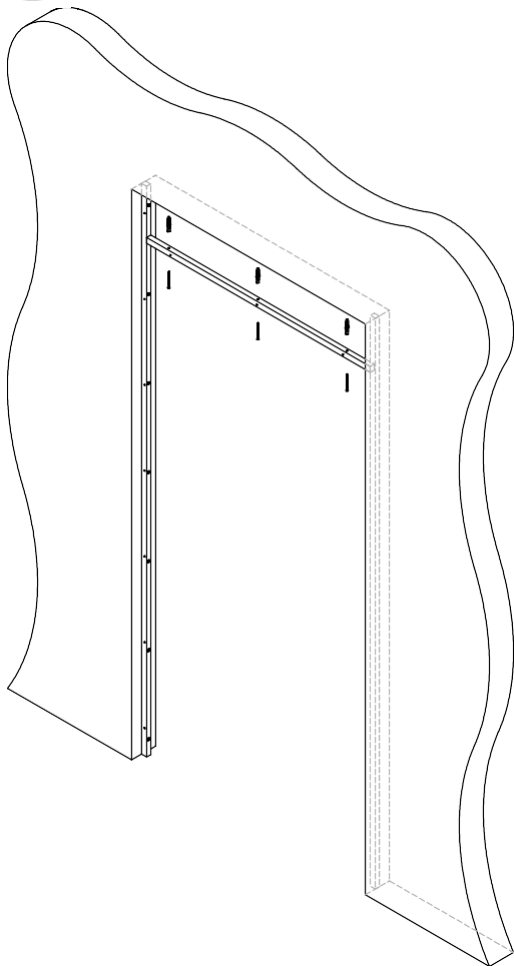

Eckverbindung des Zierbekleidungsrahmens auf Gehrung (NORMAL) - A, B

3.

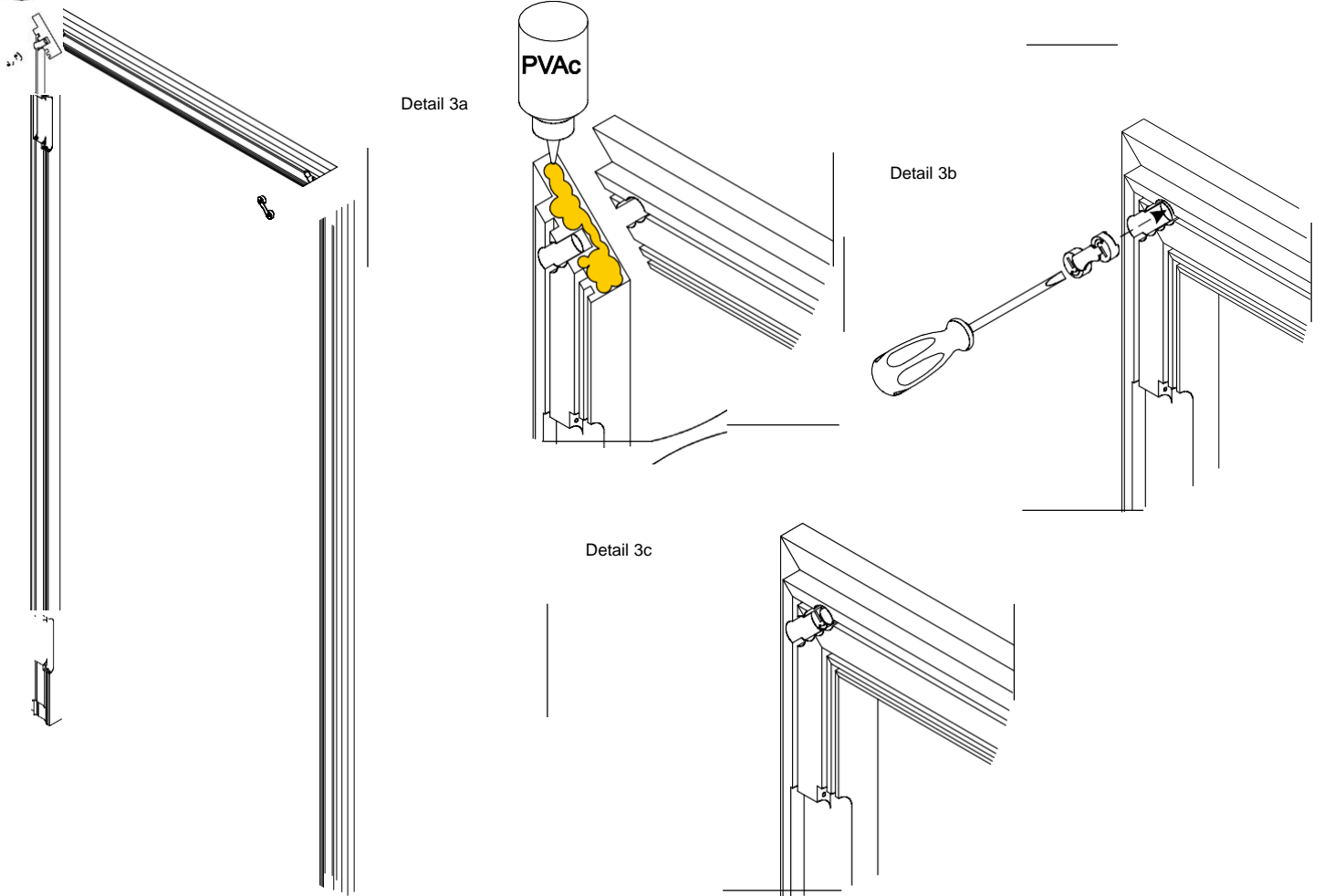

Eckverbindung des Bekleidungsrahmens auf Gehrung (NORMAL) - A, B

4.

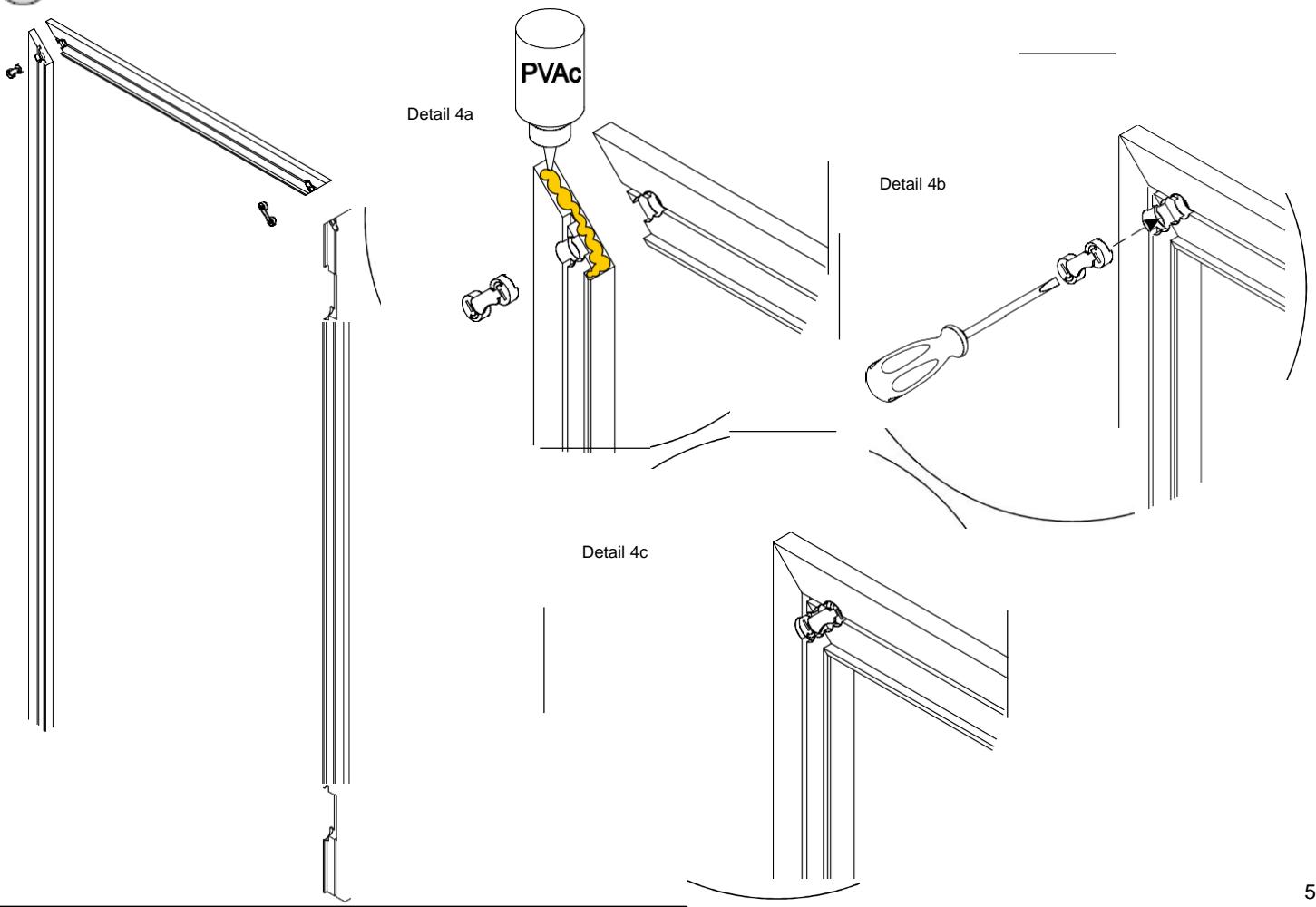

5.

Stumpfe Eckverbindung des Zierbekleidungsrahmens (OBTUS) - A, B

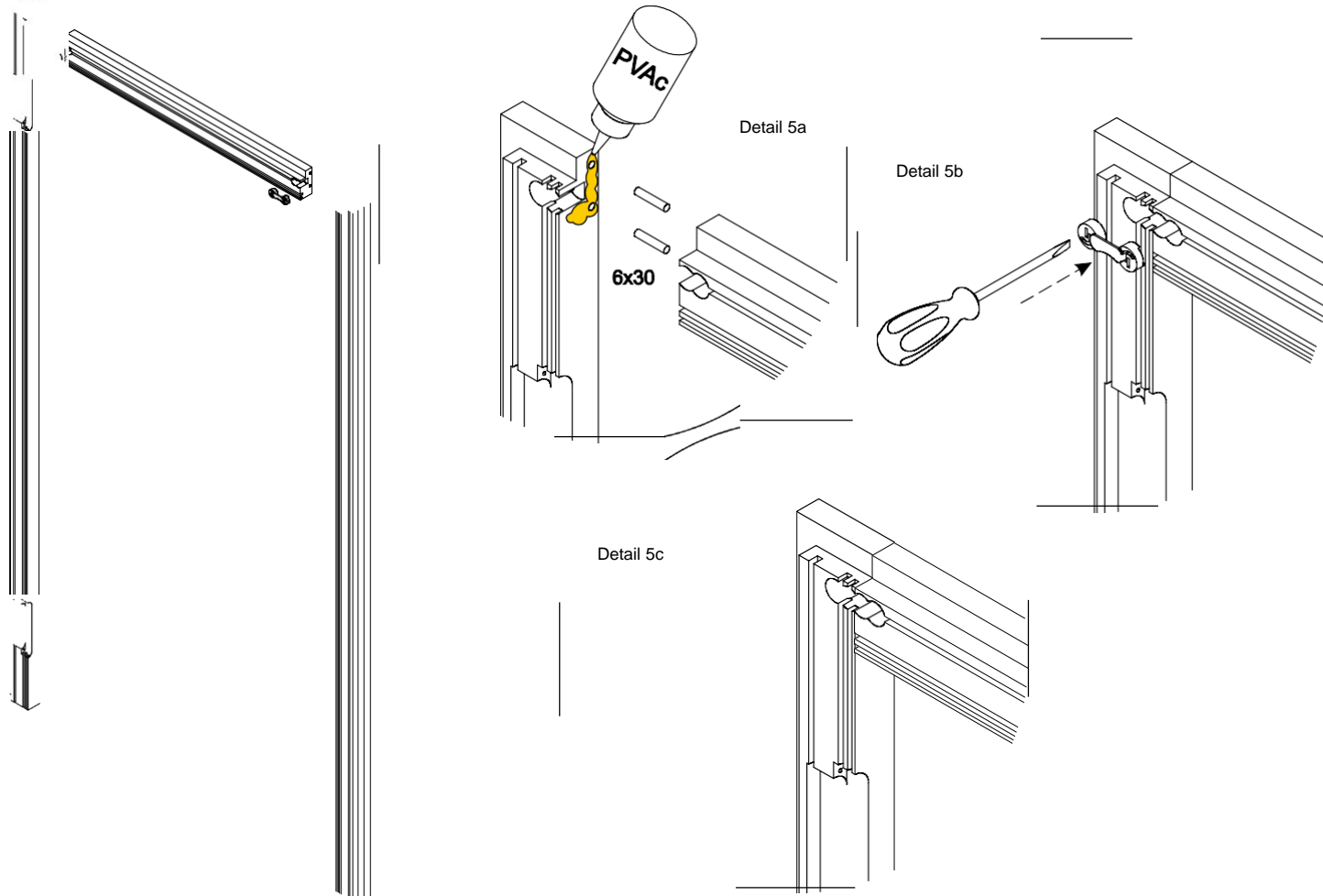

6.

Stumpfe Eckverbindung des Bekleidungsrahmens (OBTUS) - A, B

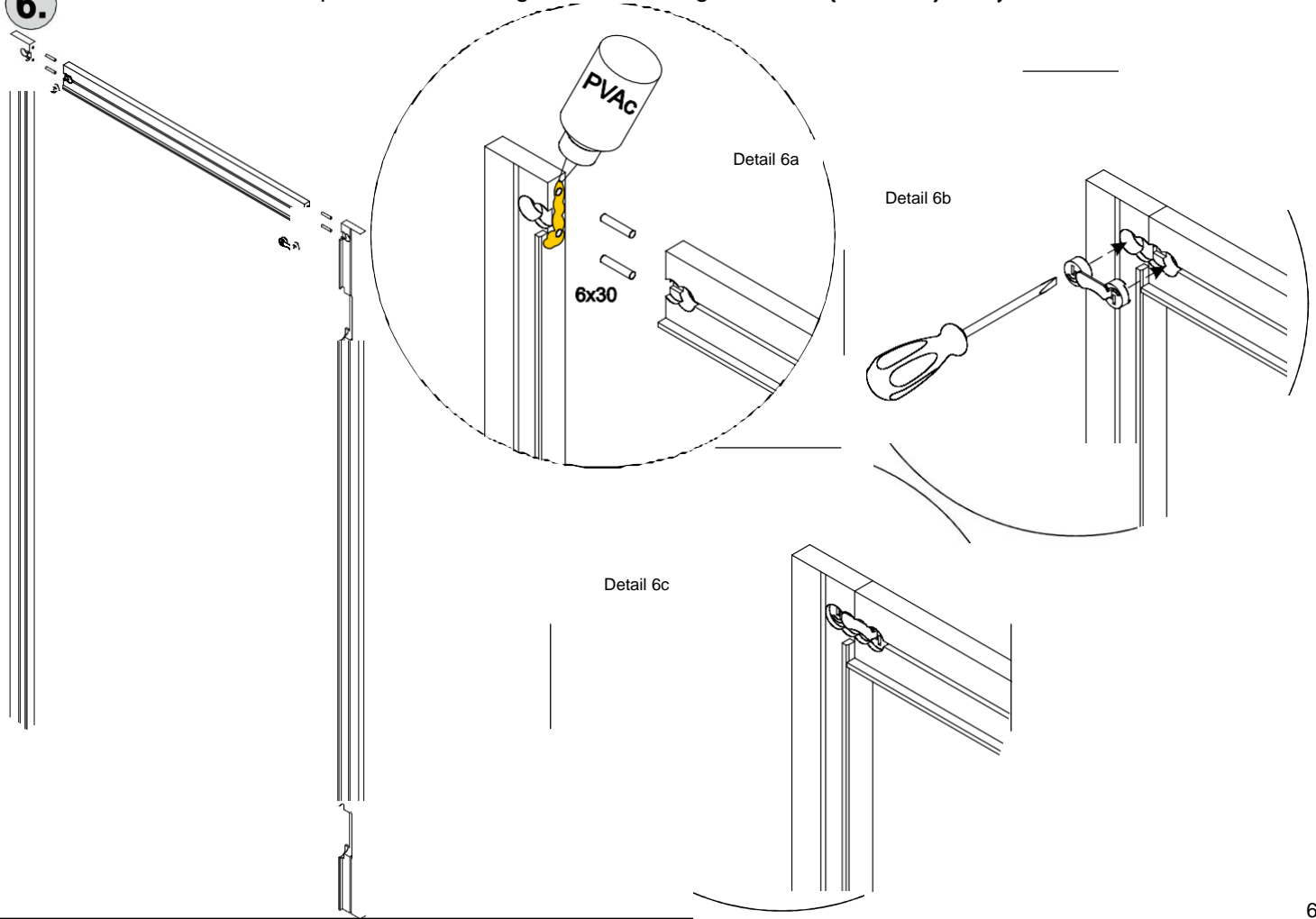

7.

Einkleben der eingesetzten Feder in die Nut des Bekleidungsrahmens - A, B

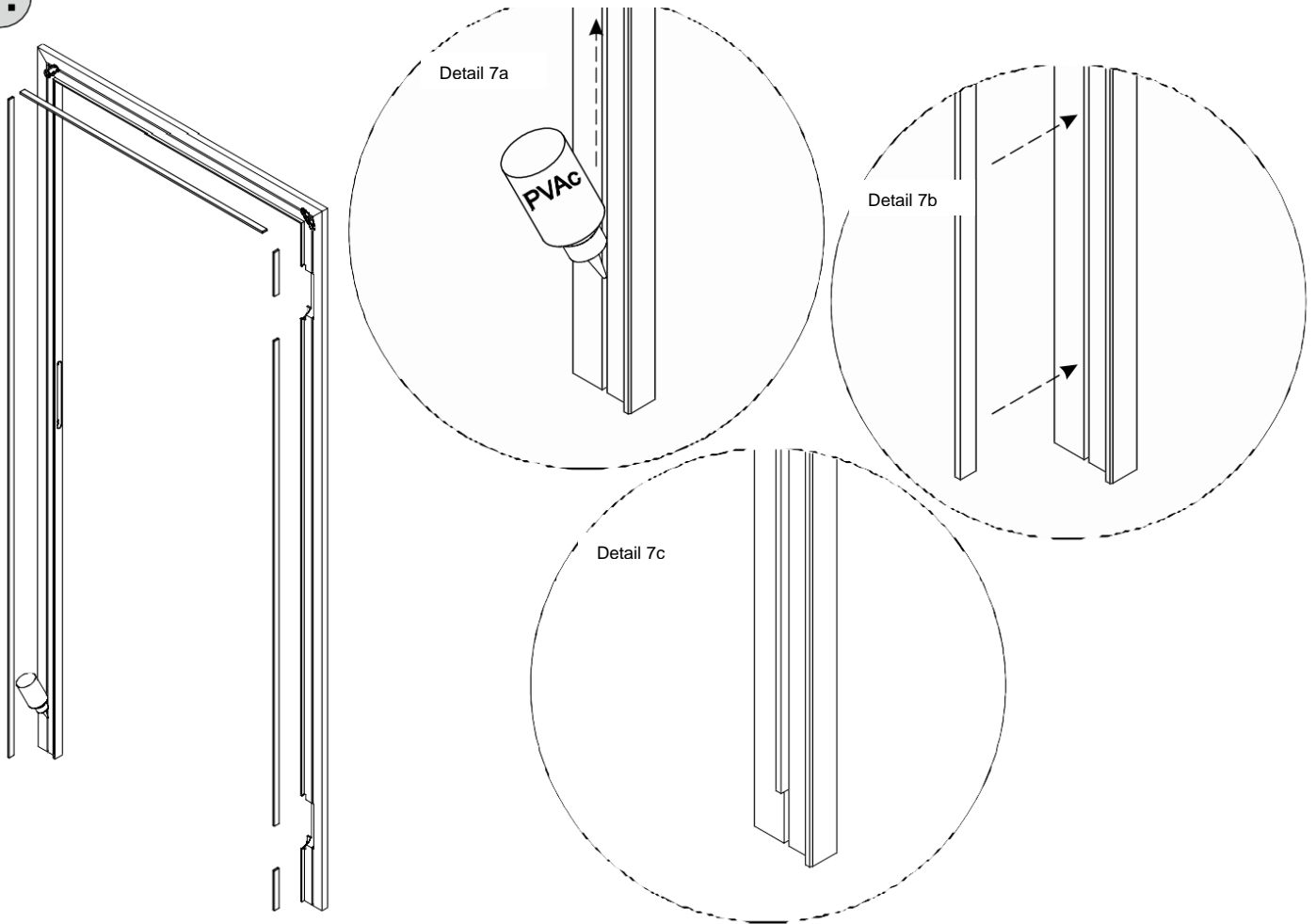

8.

Montage des Verankerungswinkels (Verankerung der Zarge an der Wand) – A, B

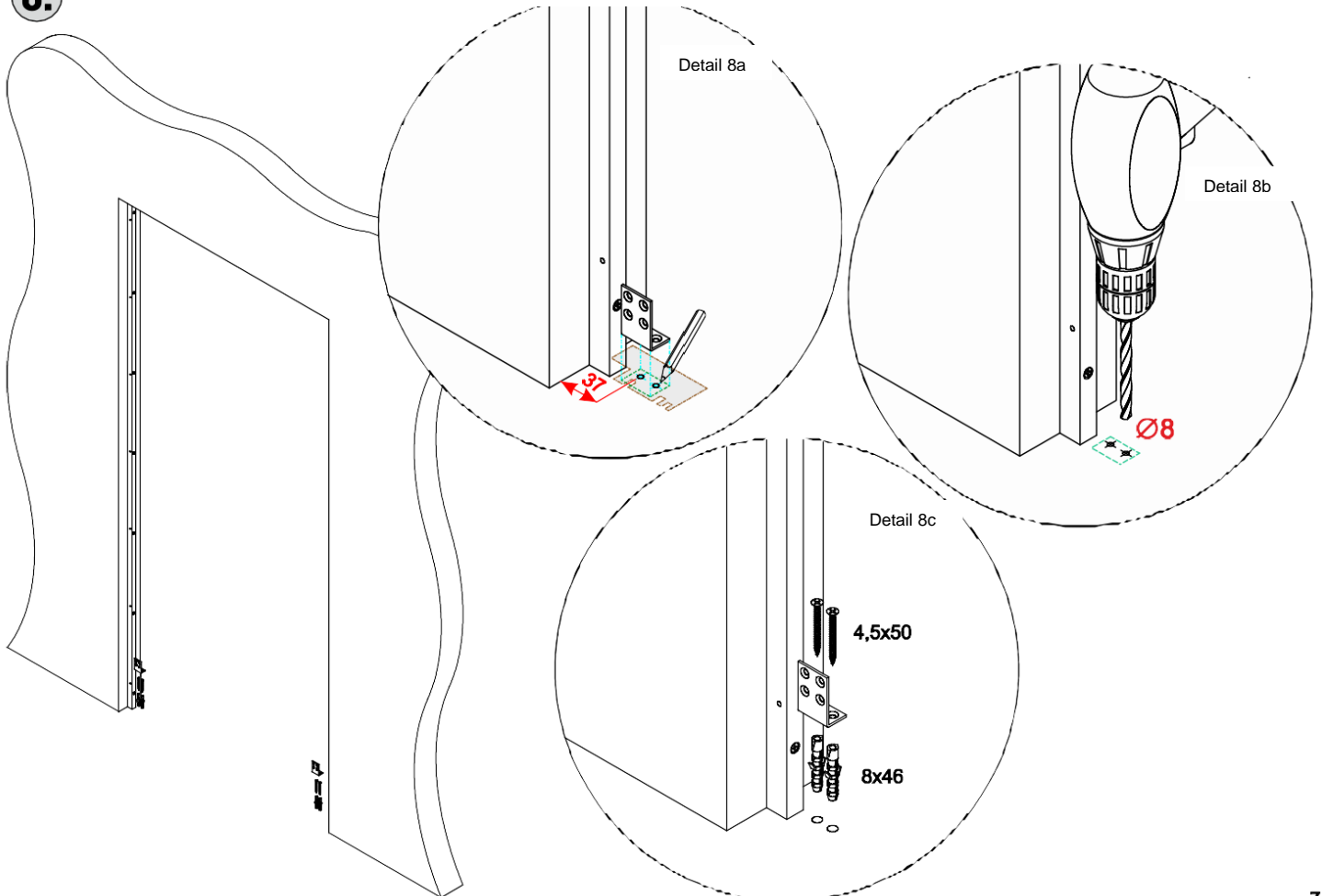

9.

Montage des Verankerungswinkels (Verankerung der Zarge am Glas des Seitenlichts) - B

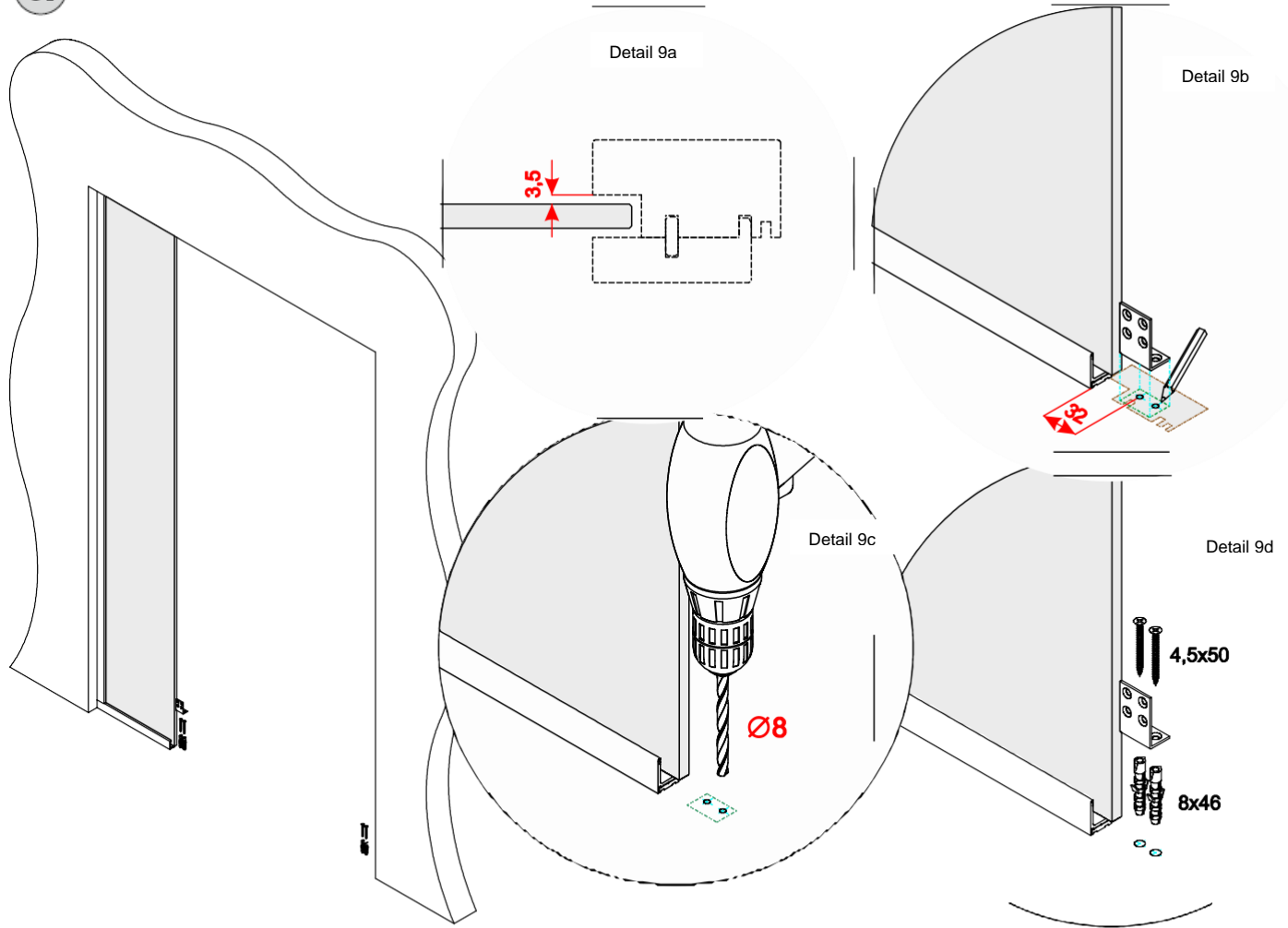

10.

Montage des Zierbekleidungsrahmens (Verankerung der Zarge am Glas des Seitenlichts) - B

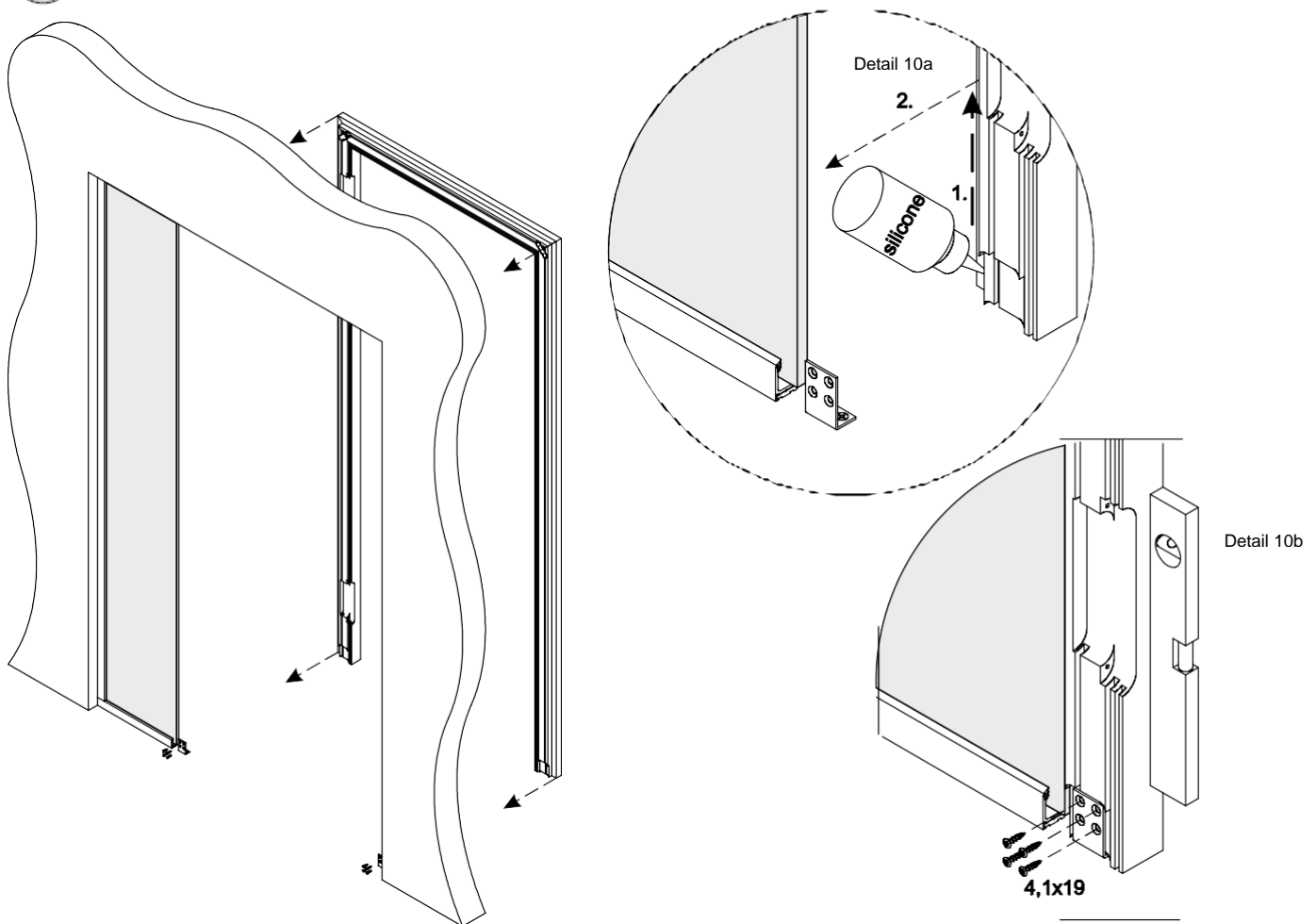

11. Montage des Zierbekleidungsrahmens (Verankerung der Zarge an der Wand) - **A, B**

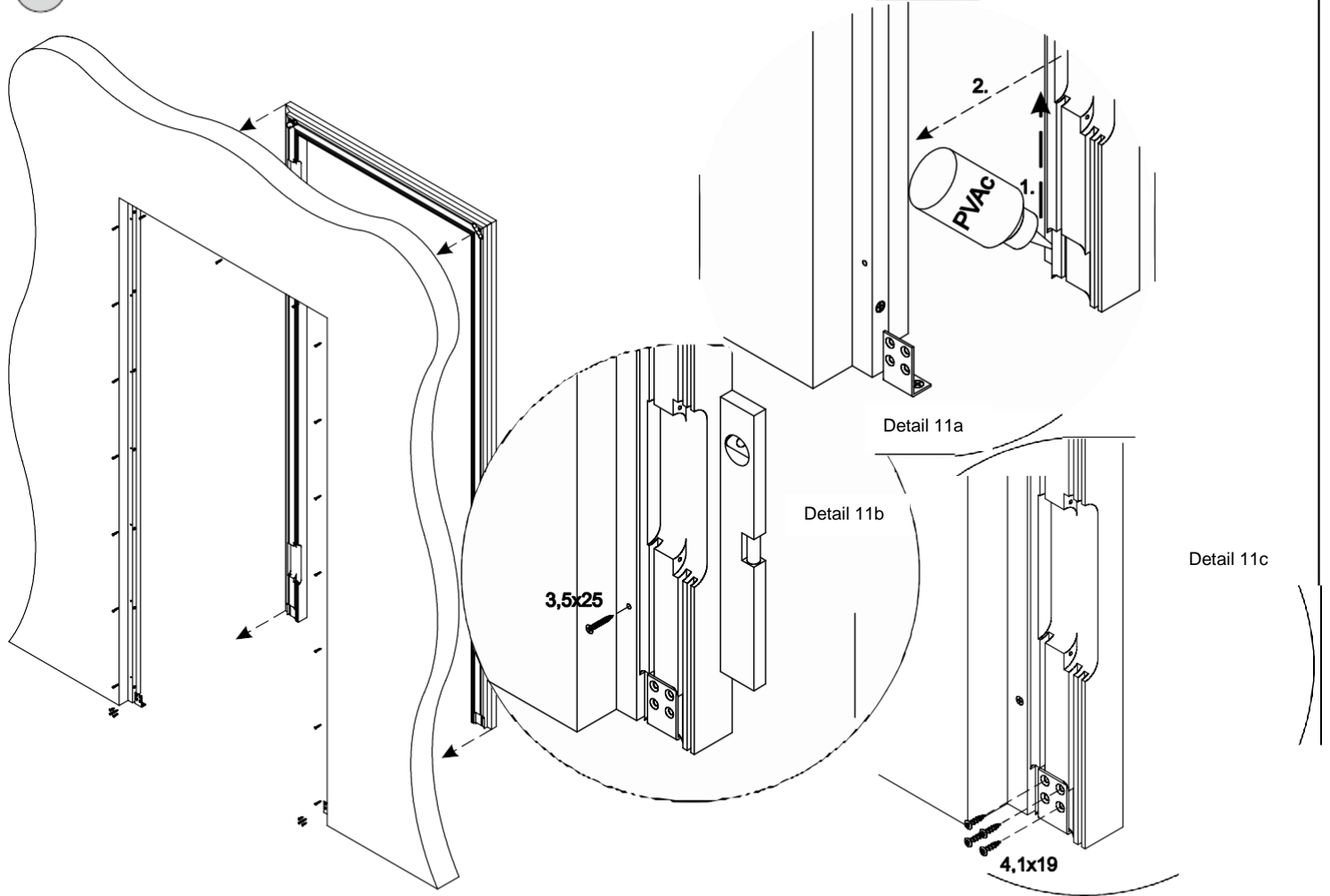

12. Montage des Bekleidungsrahmens (Verankerung der Zarge an der Wand) - **A, B**

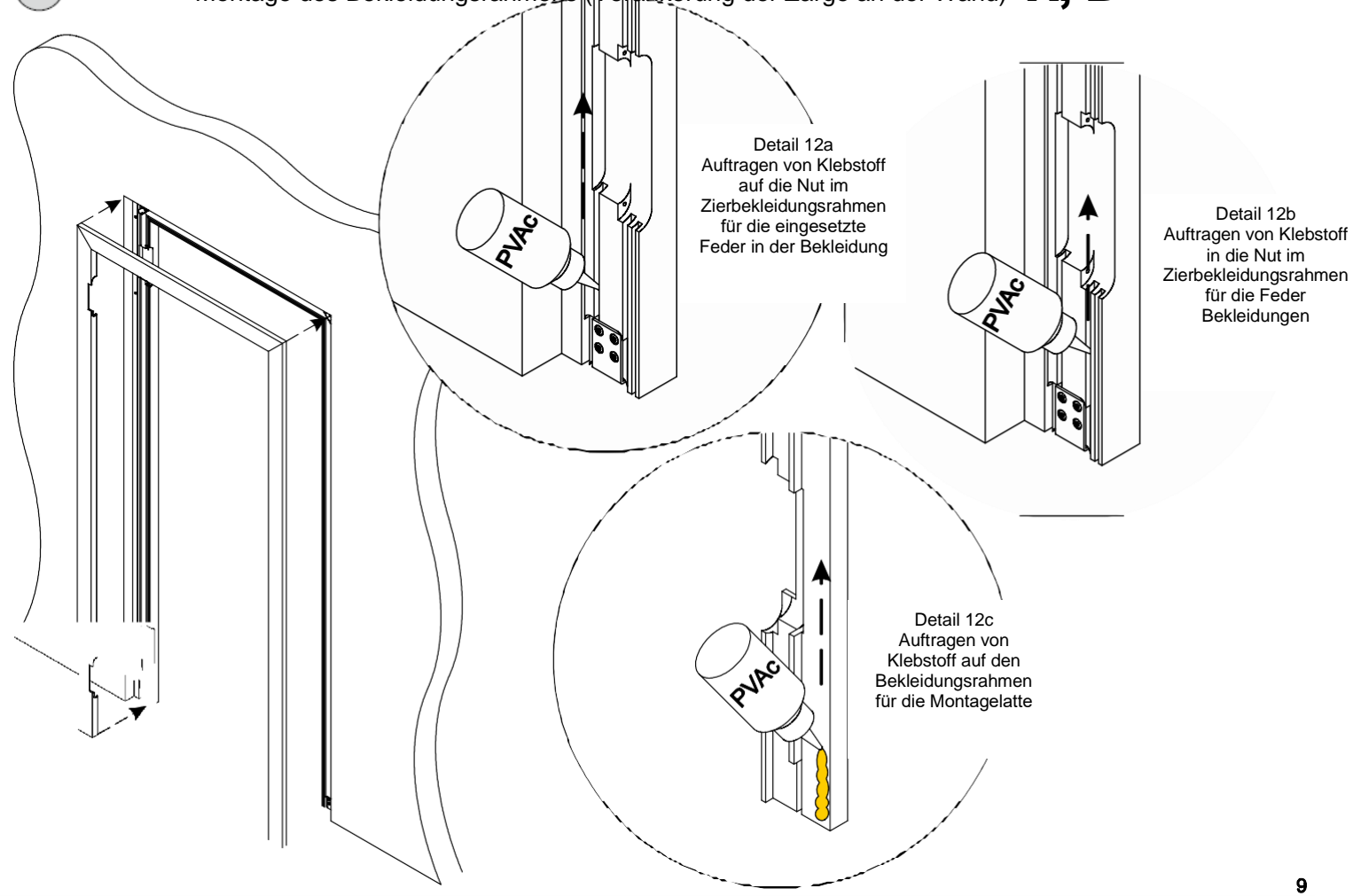

13.

Befestigung des geleimten Zargenrahmens (Verankerung der Zarge an der Wand) - **A, B**

Detail 13a

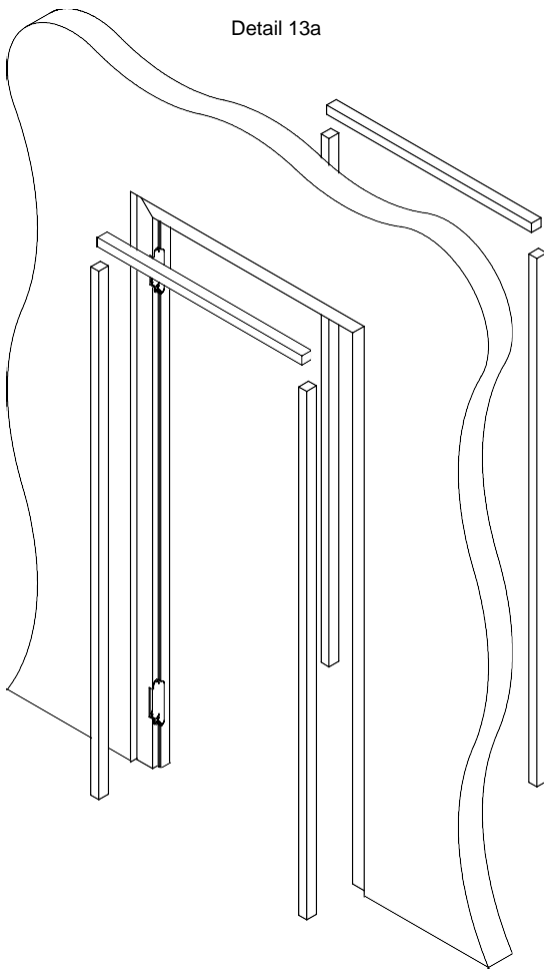

Detail 13b

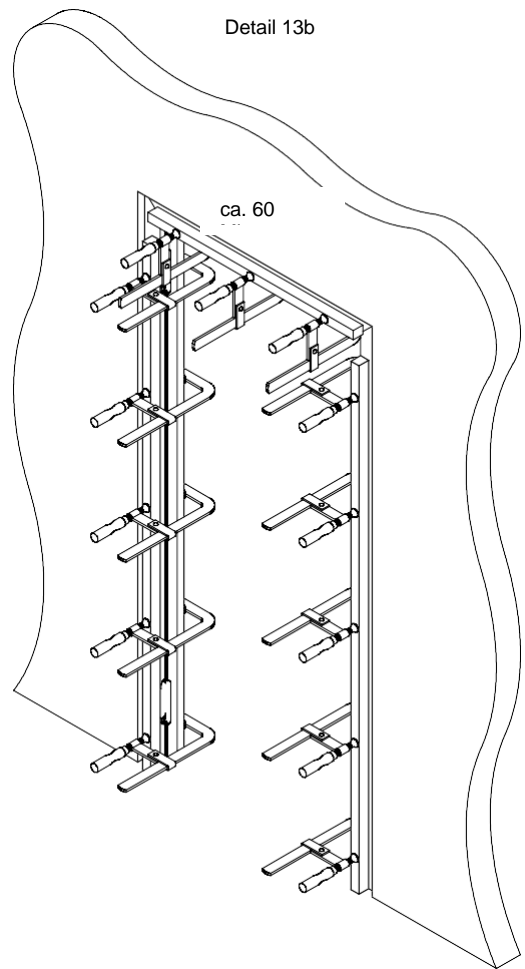

14.

Montage des Bekleidungsrahmens (Verankerung der Zarge am Glas des Seitenlichts) - **B**

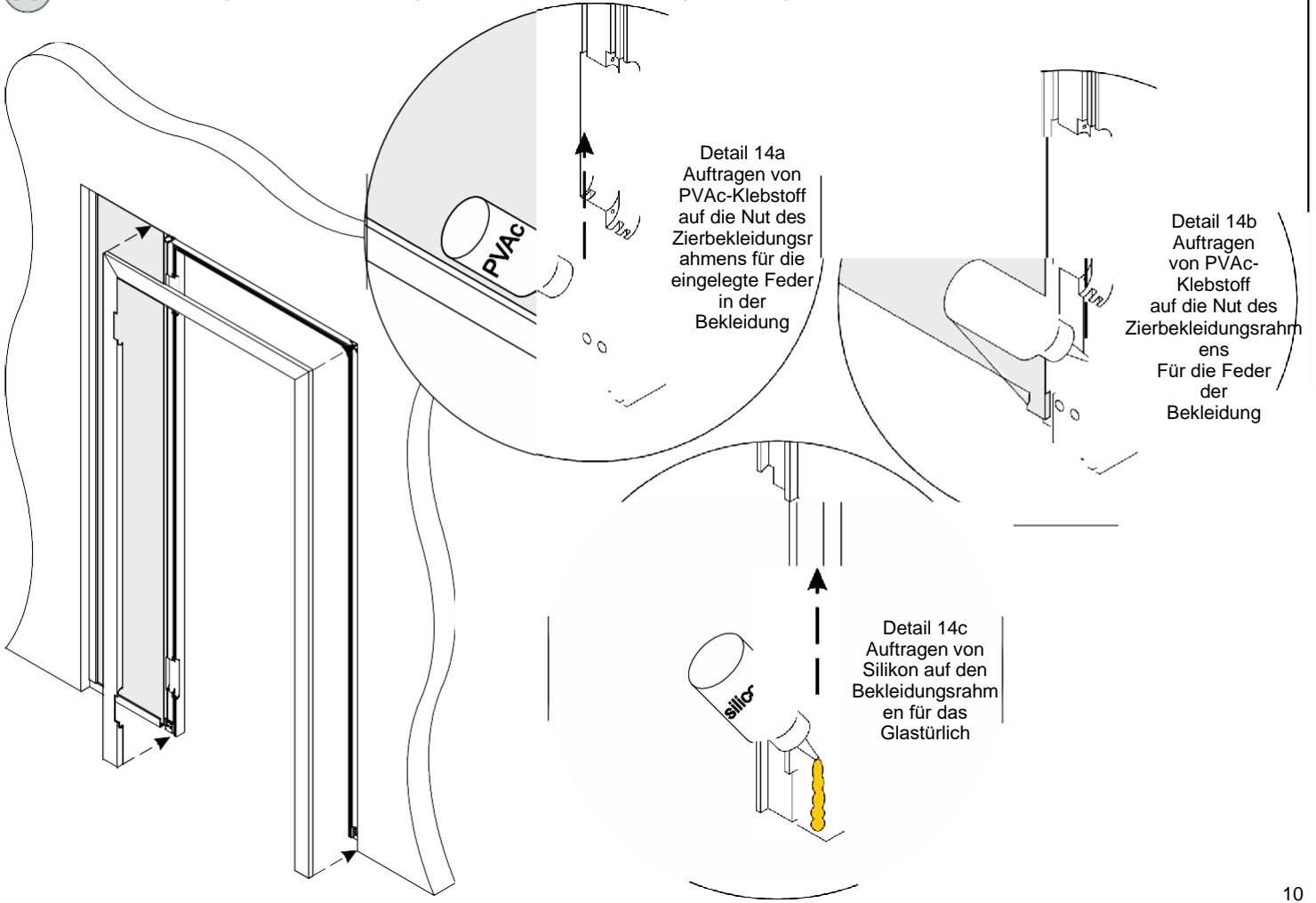

15. Befestigung des geleimten Zargenrahmens (Verankerung der Zarge am Glas des Seitenlichts) - B

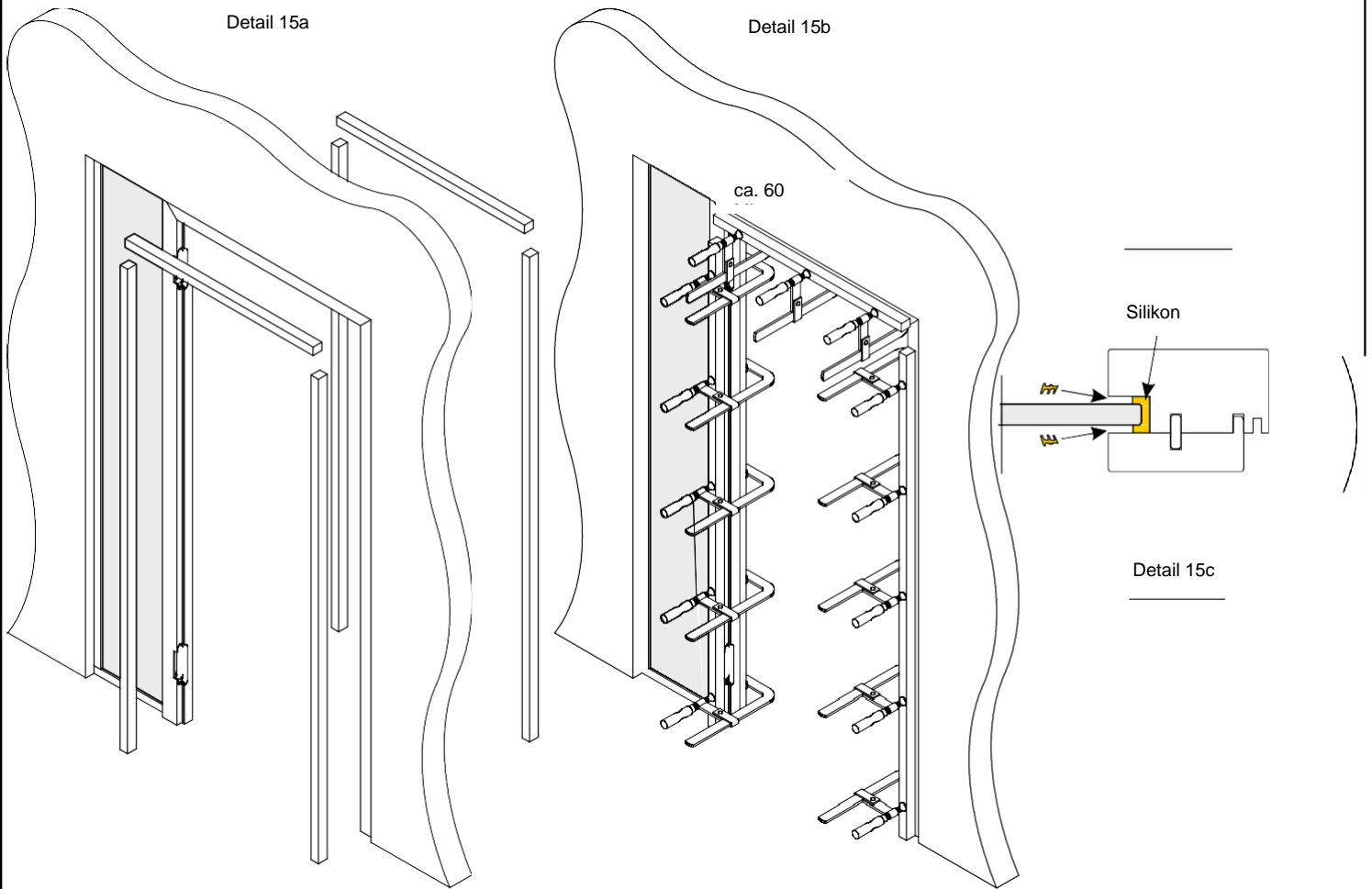

16. Einbau des Bands in die Zarge - A, B

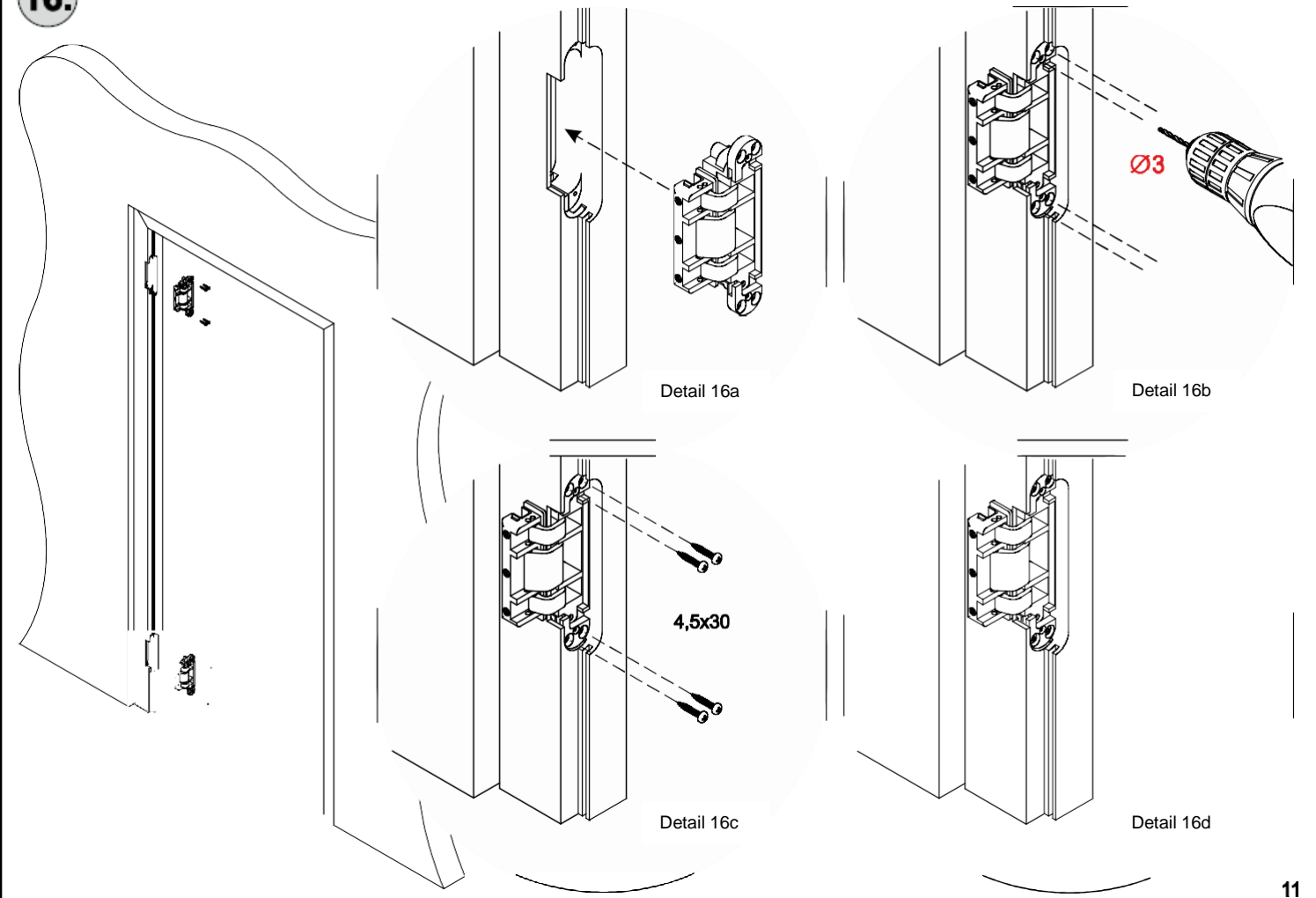

17.

Einsetzen der Stirnabdeckung des Bands in die Aussparung der Zarge - A, B

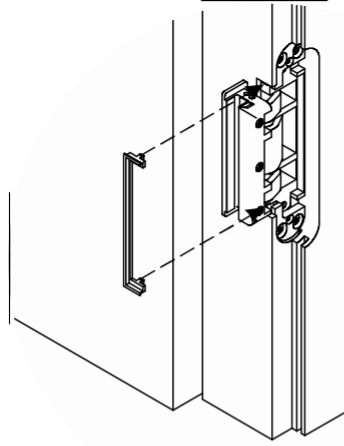
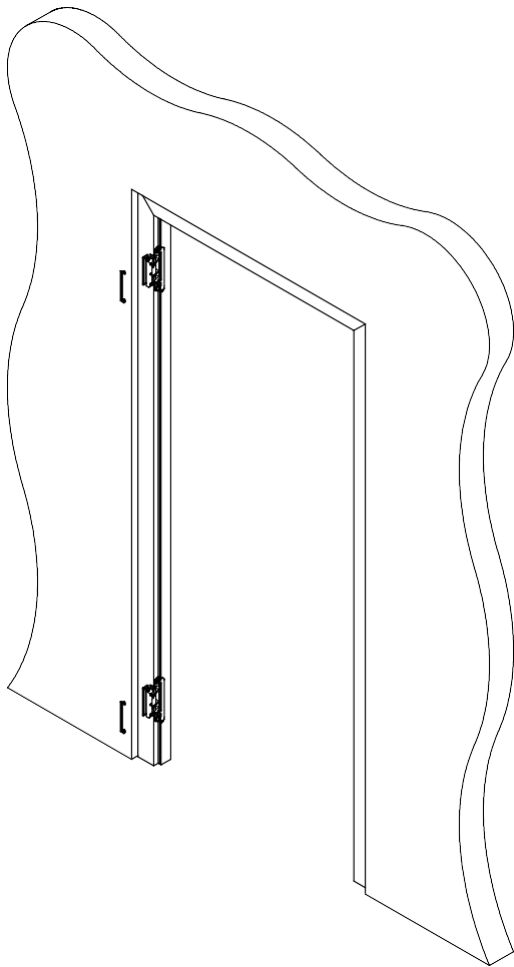

Detail 17a

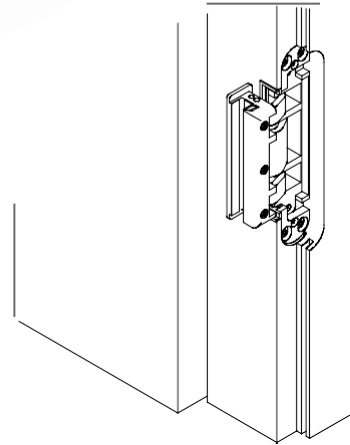

Detail 17b

18.

Einsetzen des Glastürblatts in das Band - A, B

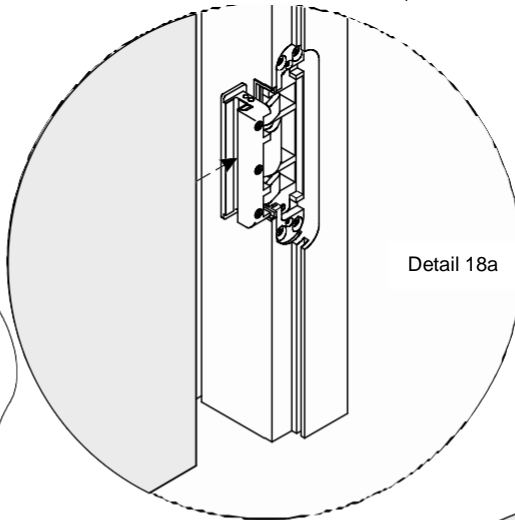
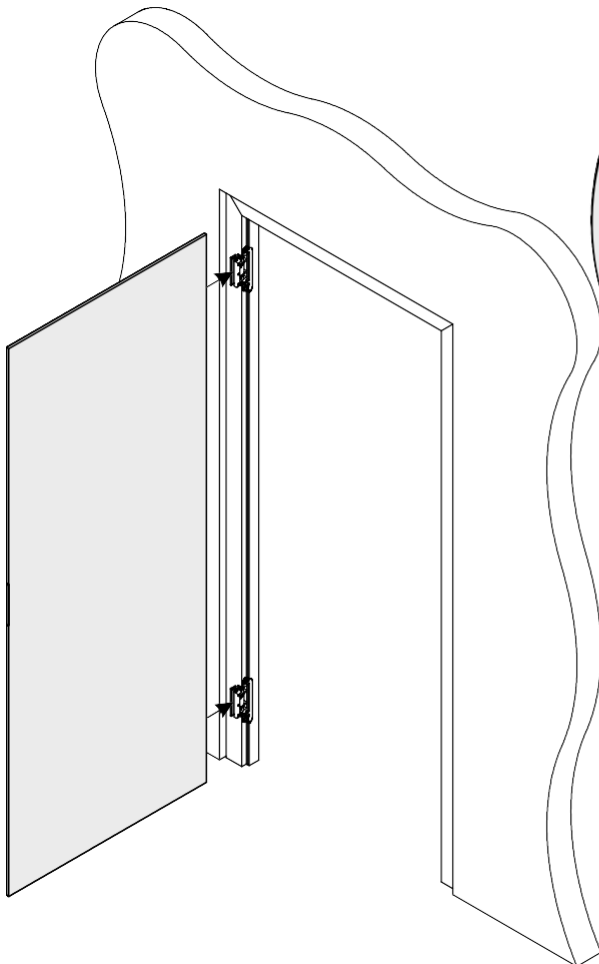

Detail 18a

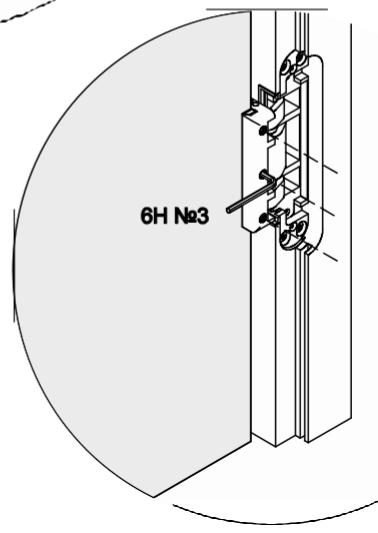

Detail 18b

19.

Höhenverstellung des Türblatts in der Zarge -A, B

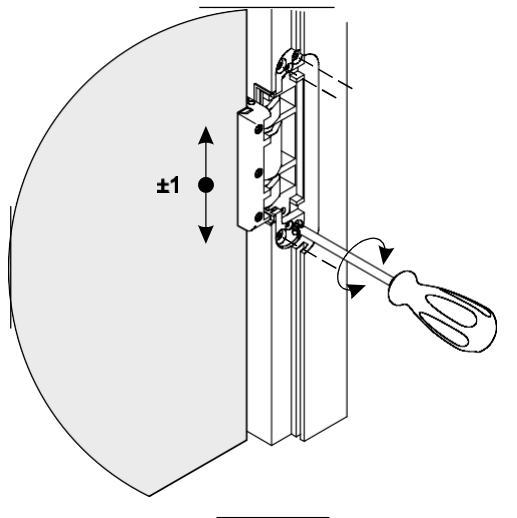
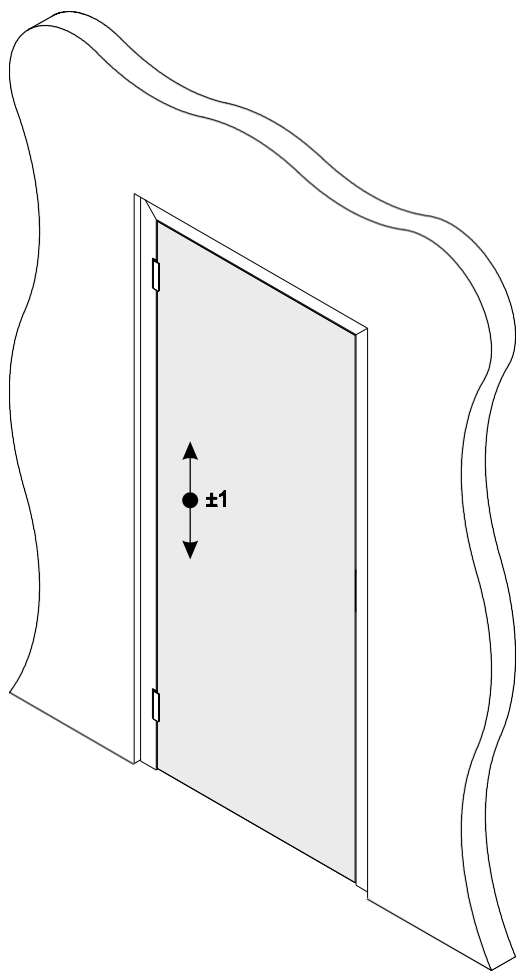

20.

Seitliche Verstellung des Türblatts in der Zarge - A, B

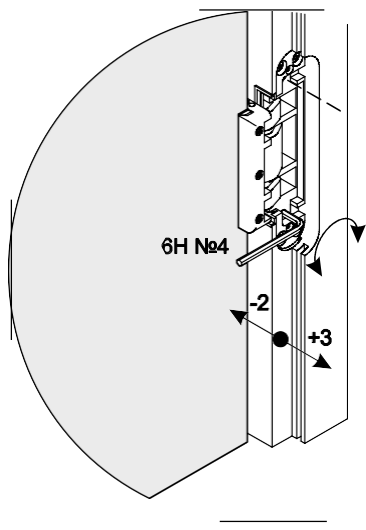
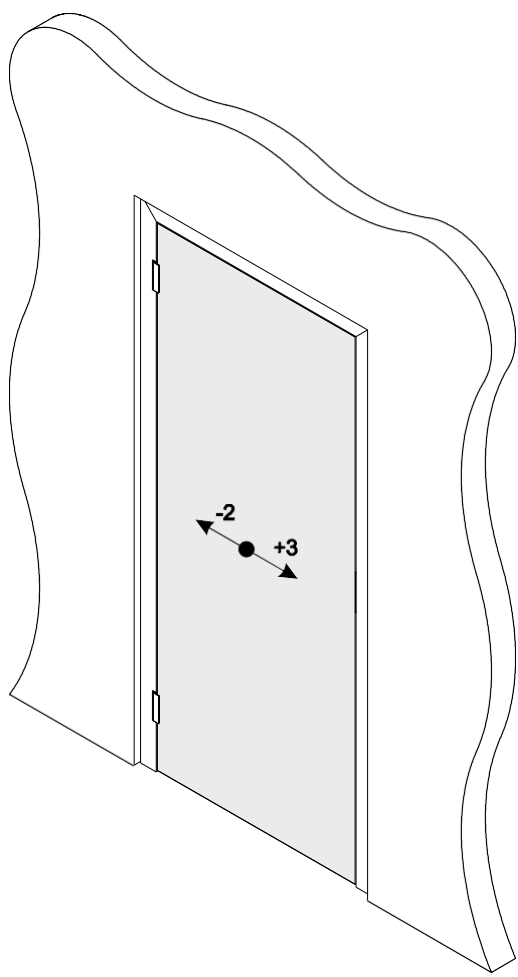

21.

Montáž krycí závěsu A, B

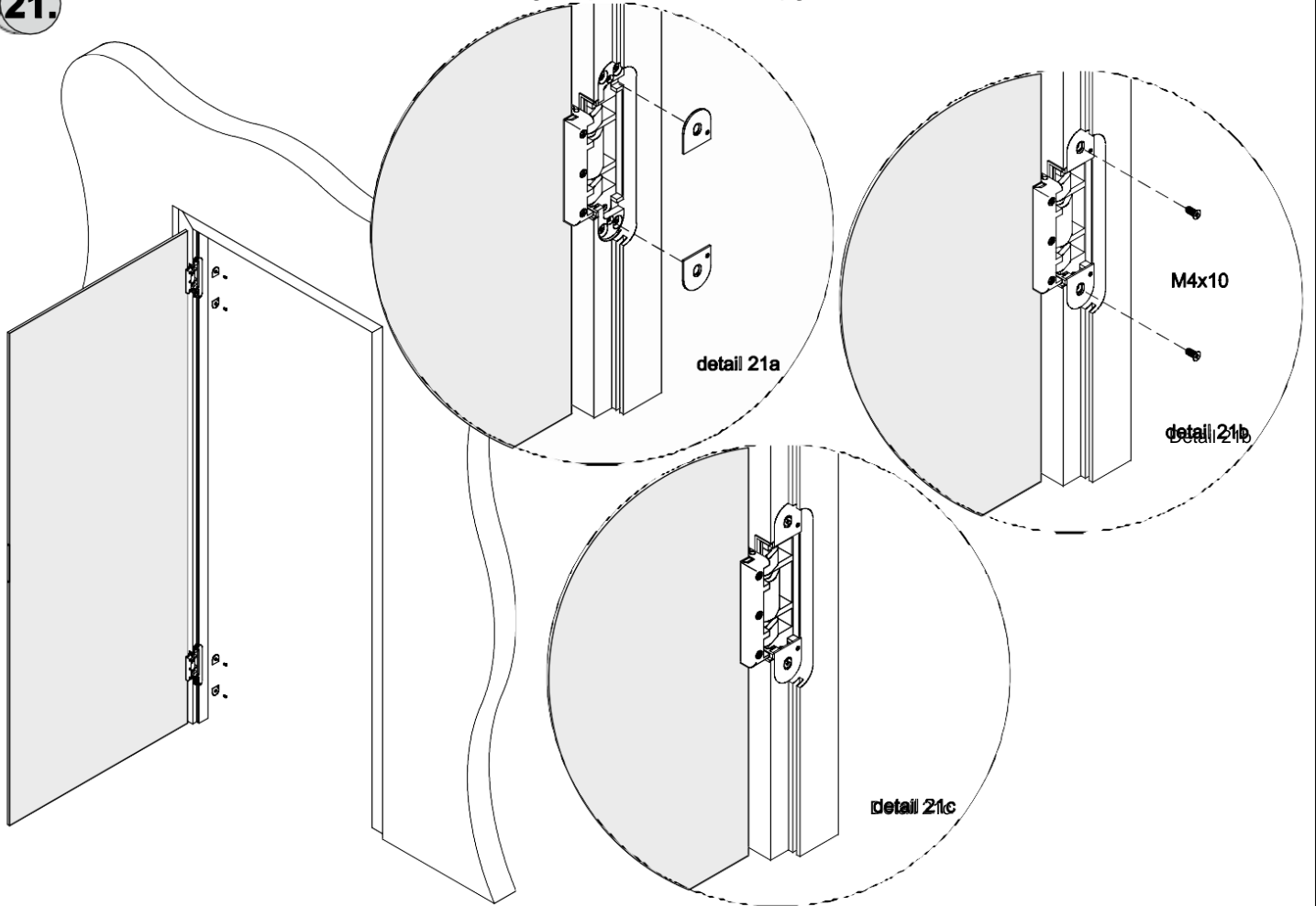

22.

Montáž krytek poddrážky závěsu A, B

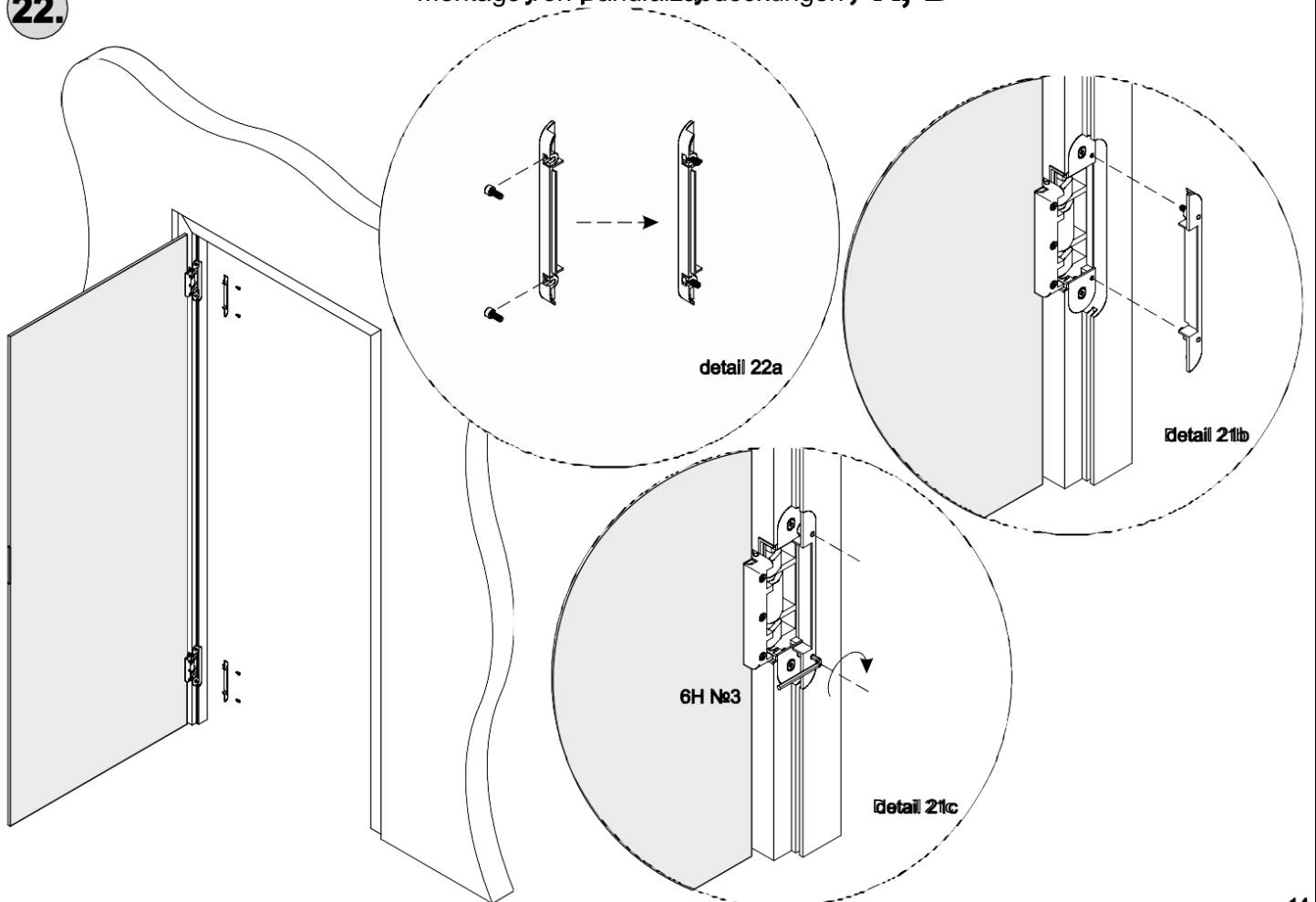

23.

Montage und Einstellung des Magneten - A, B

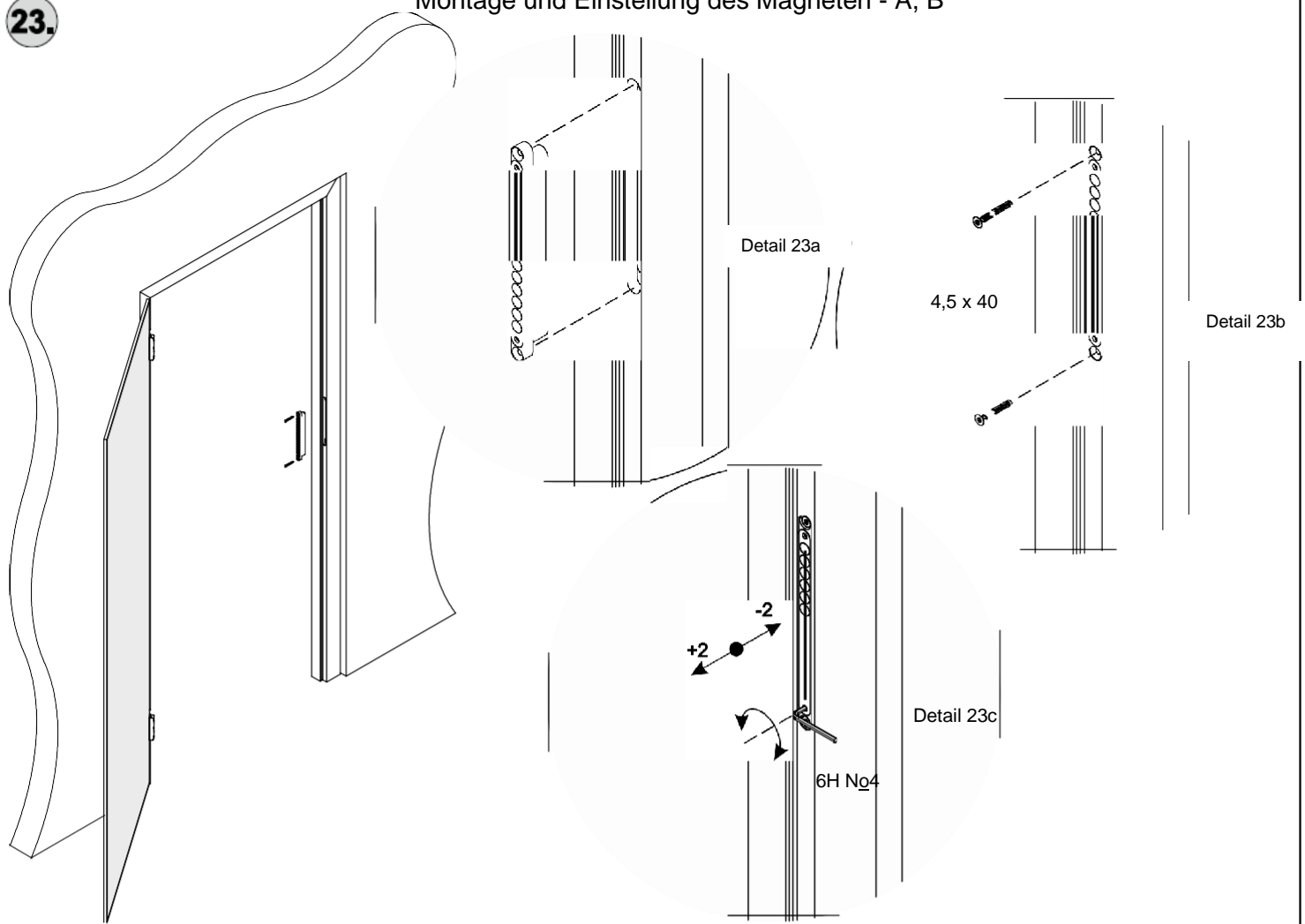

24.

Dichtungsmontage - A, B

