

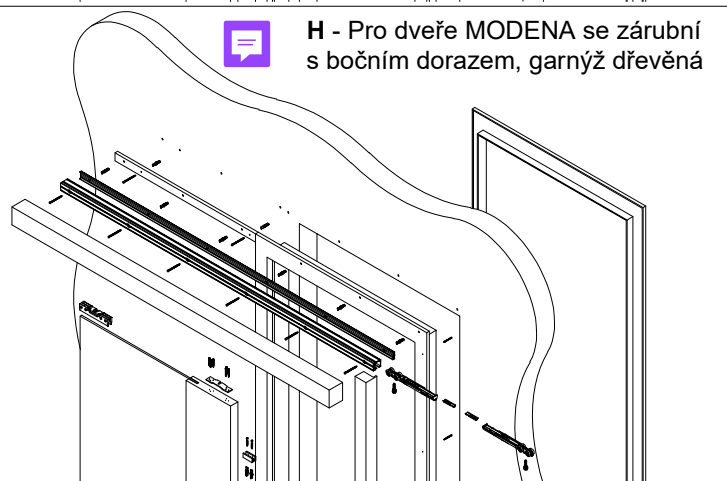

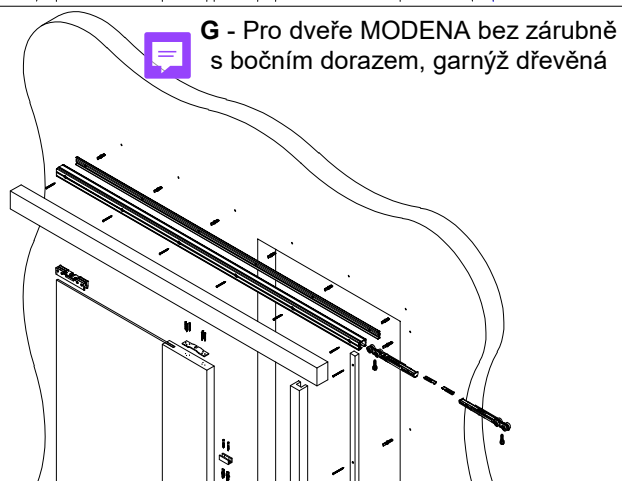

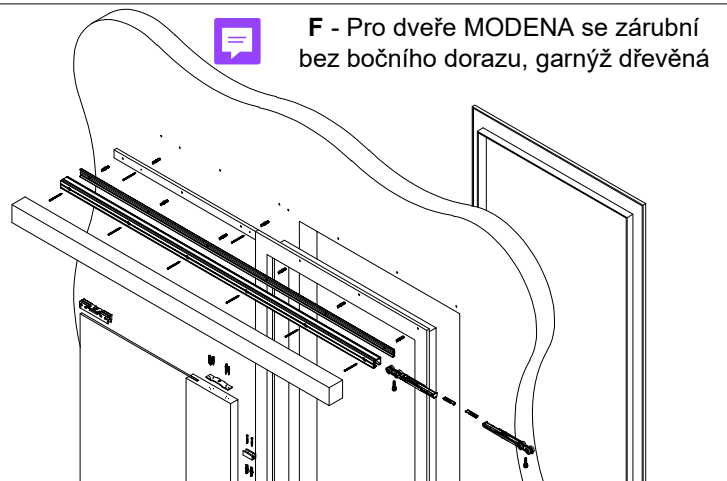

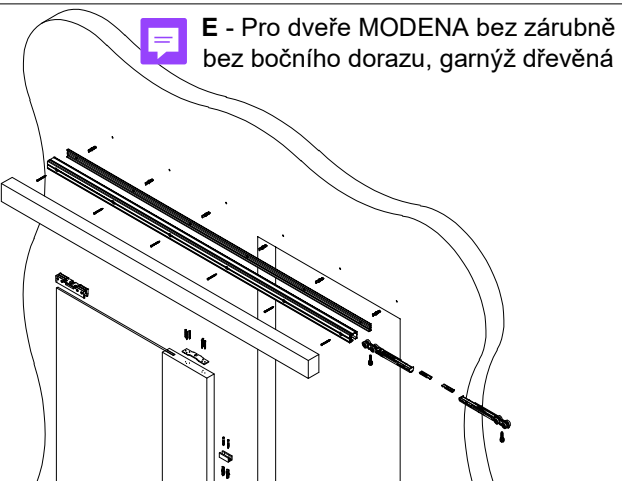

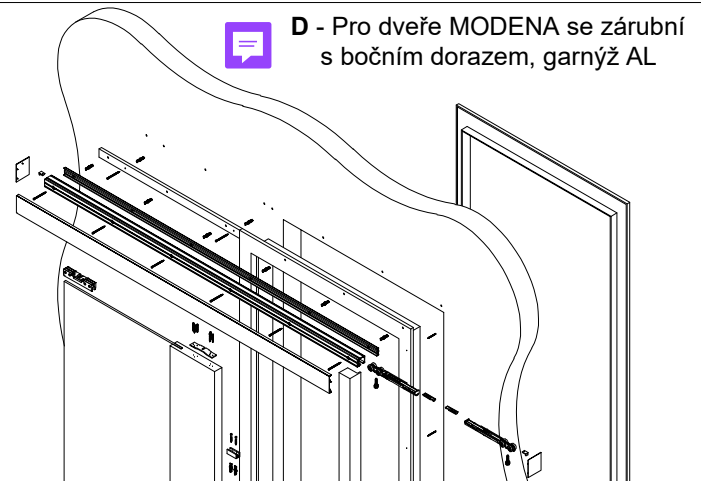
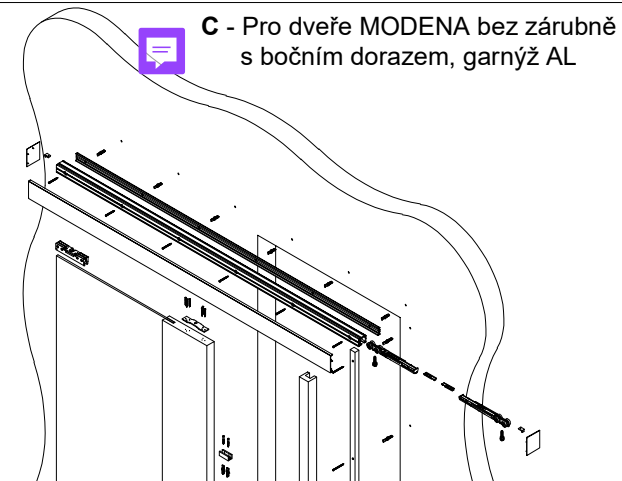
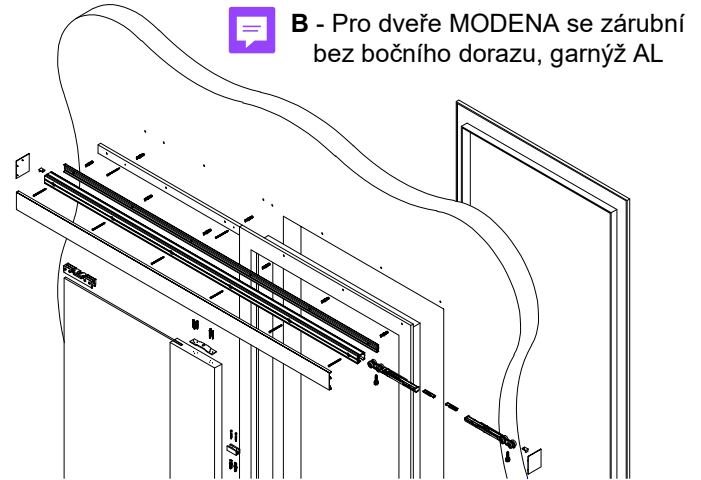
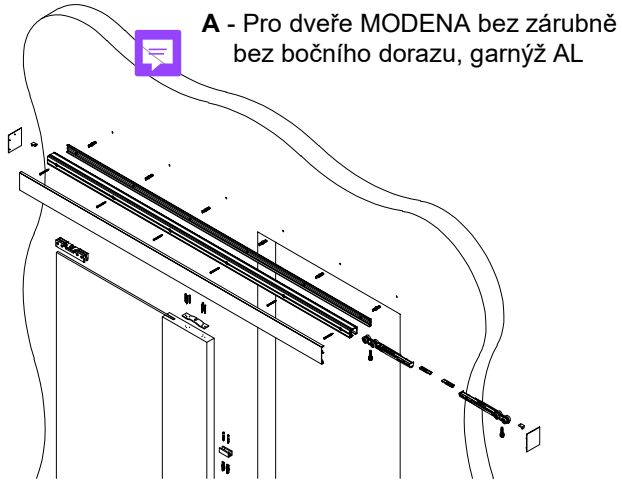
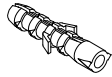
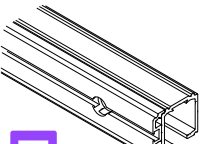
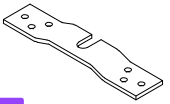

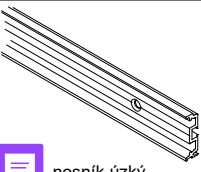

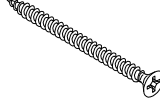
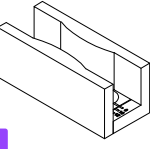
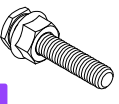
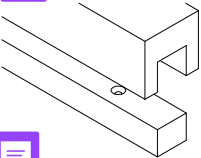
Před započítím montáže doporučujeme pečlivě přečíst montážní návod, případně svěřit montáž speciálně vyškoleným pracovníkům.

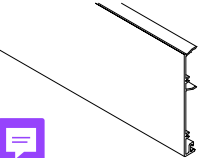
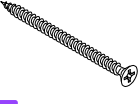
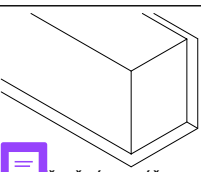

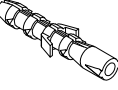
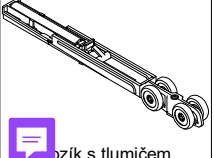
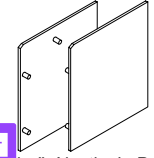
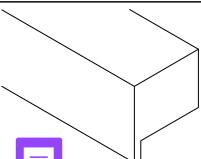
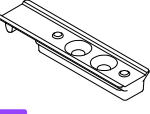
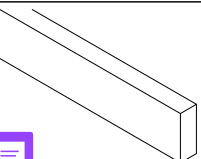
| | A | B | C | D | E | F | G | H | | A | B | C | D | E | F | G | H | | A | B | C | D | E | F | G | H | |
|--|---|---|---|---|---|---|---|---|--|---|---|---|---|---|---|---|---|--|---|---|---|---|---|---|---|---|--|
|  noždinka 8x40 | ✓ | ✓ | ✓ | ✓ | ✓ | ✓ | ✓ | ✓ |  kolejnice | ✓ | ✓ | ✓ | ✓ | ✓ | ✓ | ✓ | ✓ |  držák dřevěného křídla | ✓ | ✓ | ✓ | ✓ | ✓ | ✓ | ✓ | ✓ | |
|  vrut 5x50 | ✓ | | ✓ | | ✓ | | ✓ | |  nosník úzký | ✓ | ✓ | ✓ | ✓ | ✓ | ✓ | ✓ | ✓ |  vrut 4x40 | ✓ | ✓ | ✓ | ✓ | ✓ | ✓ | ✓ | ✓ | |
|  vrut 5x70 | ✓ | | ✓ | | ✓ | | ✓ | |  vodítko DORMA | ✓ | ✓ | ✓ | ✓ | ✓ | ✓ | ✓ | ✓ |  šroub M8x40 + kontramatka | ✓ | ✓ | ✓ | ✓ | ✓ | ✓ | ✓ | ✓ | |
|  boční doraz bez zárubně* | | | ✓ | | | | ✓ | |  vrut 5x40 | ✓ | ✓ | ✓ | ✓ | ✓ | ✓ | ✓ | ✓ |  AL čelo kolejnice 85 | ✓ | ✓ | ✓ | ✓ | | | | | |
|  vrut 4x60** | | | ✓ | | | | ✓ | |  dřevěná garnýž | | | | | | ✓ | ✓ | ✓ |  držák boční krytky | ✓ | ✓ | ✓ | ✓ | | | | | |
|  noždinka 8x50** | | | ✓ | | | | ✓ | |  vozík s tlumičem | ✓ | ✓ | ✓ | ✓ | ✓ | ✓ | ✓ | ✓ |  boční krytka L+P | ✓ | ✓ | ✓ | ✓ | | | | | |
|  boční doraz pro záruběň* | | | | ✓ | | | | ✓ |  aktivátor | ✓ | ✓ | ✓ | ✓ | ✓ | ✓ | ✓ | ✓ |  distanční lišta | | | ✓ | | ✓ | | ✓ | ✓ | |
|  vrut 3,5x45** | | | | ✓ | | | | ✓ |  držák skla VETRO 22 | ✓ | ✓ | ✓ | ✓ | ✓ | ✓ | ✓ | ✓ |  klíč 6H 13 | ✓ | ✓ | ✓ | ✓ | ✓ | ✓ | ✓ | ✓ | |
|  * Boční doraz je volitelný díl, dodává se pouze je-li objednáno * Dodává se k volitelnému bočnímu dorazu | | | | | | | | | | | | | | | | | | | | | | | | | | | |
| <p>Skutečné počty jednotlivých komponent se dodávají dle počtu křídel, délky posuvu či specifikace zákazníka.</p> | | | | | | | | | | | | | | | | | | | | | | | | | | | |

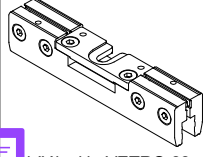
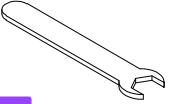
 /áhy a minimální rozměry křídla pro vozíky s tlumičem

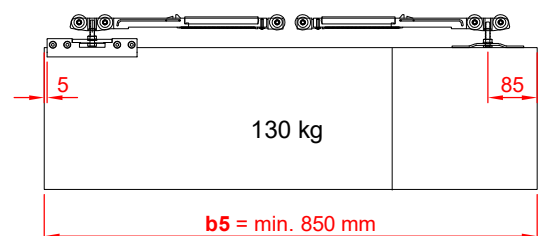
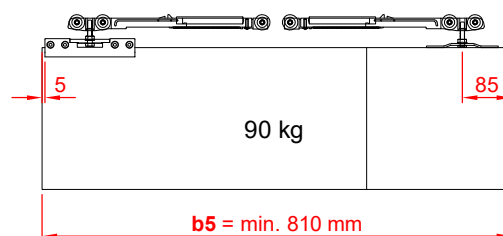
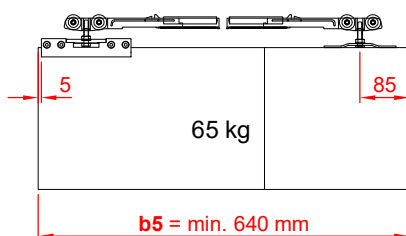



1. MONTÁŽNÍ ROZMĚRY

Dveře MODENA bez zárubně



bez bočního dorazu **A, E**

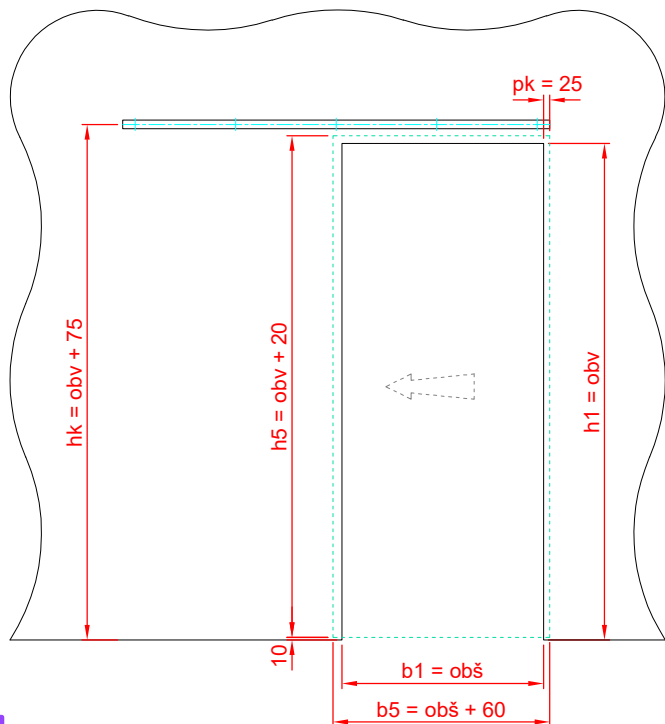

s bočním dorazem **C, G**

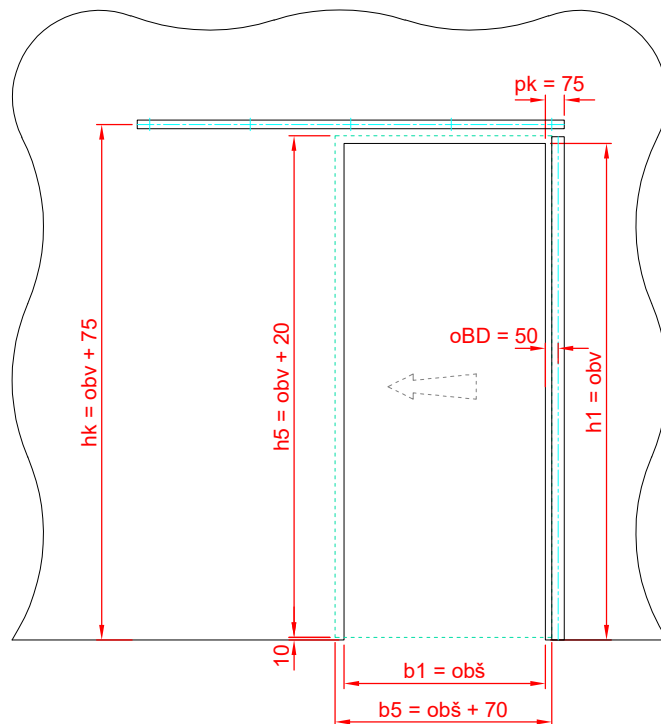

- obš - objednáací šířka
- obv - objednáací výška
- pk - přesah kolejnice (dřevěné části křídla) přes otvor
- hk - výška osy vrtání kolejnice
- oBD - osa vrtání pro boční doraz od otvoru



- b1 - průchozí šířka otvoru bez zárubně
- h1 - průchozí výška otvoru bez zárubně
- b5 - šířka křídla MODENA
- h5 - výška křídla MODENA
- směr otevírání



Dveře MODENA se zárubní



bez bočního dorazu **B, F**

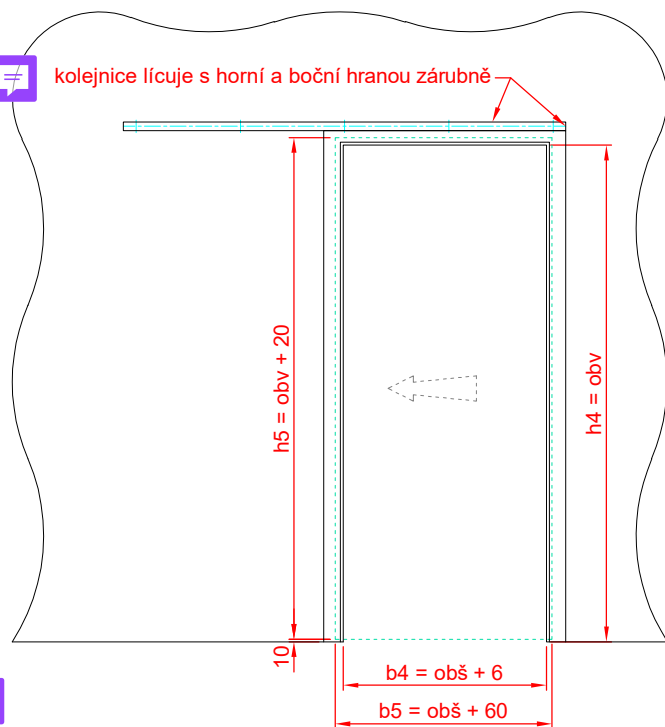

s bočním dorazem **D, H**

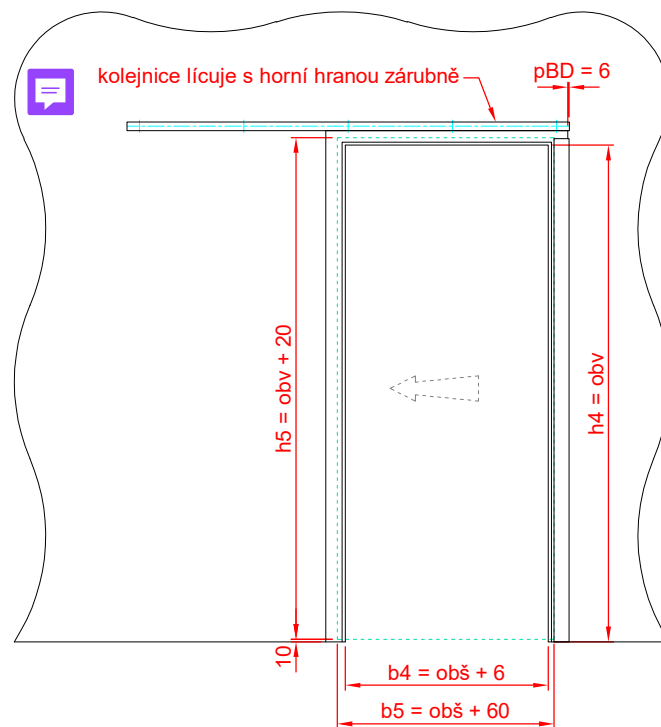

- obš - objednáací šířka
- obv - objednáací výška
- b4 - průchozí šířka zárubně
- h4 - průchozí výška zárubně
- b5 - šířka křídla MODENA
- h5 - výška křídla MODENA
- směr otevírání



2. MONTÁŽ KOLEJNICE - bez zárubně (A, C, E, G)

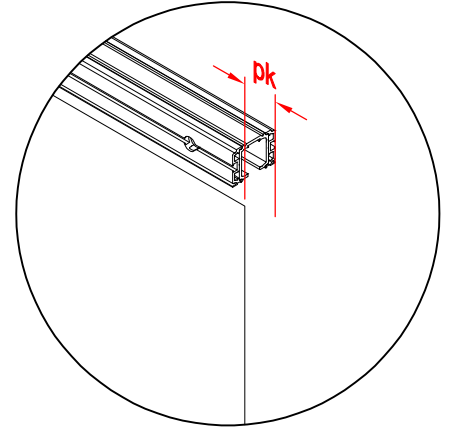
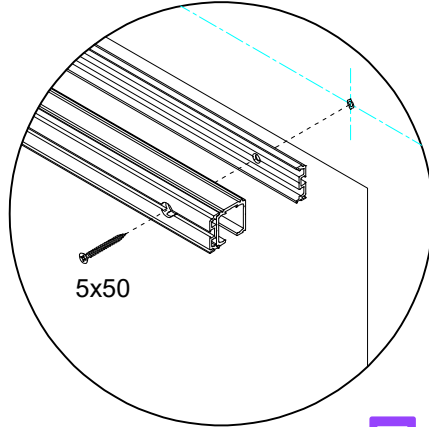
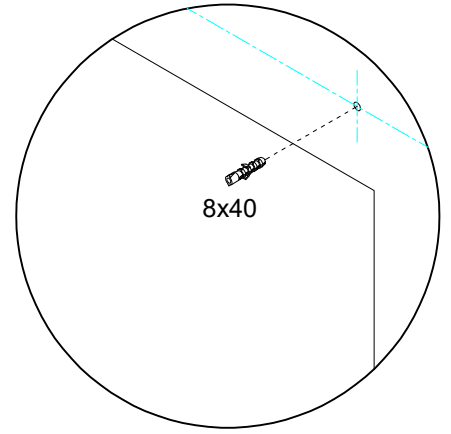
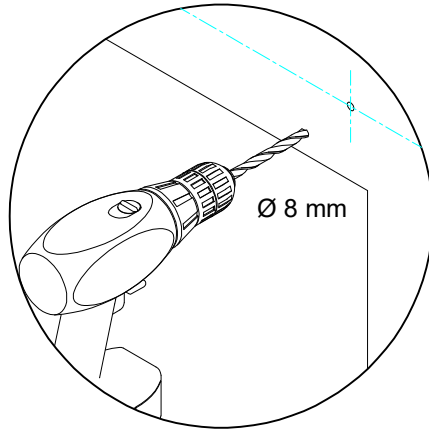
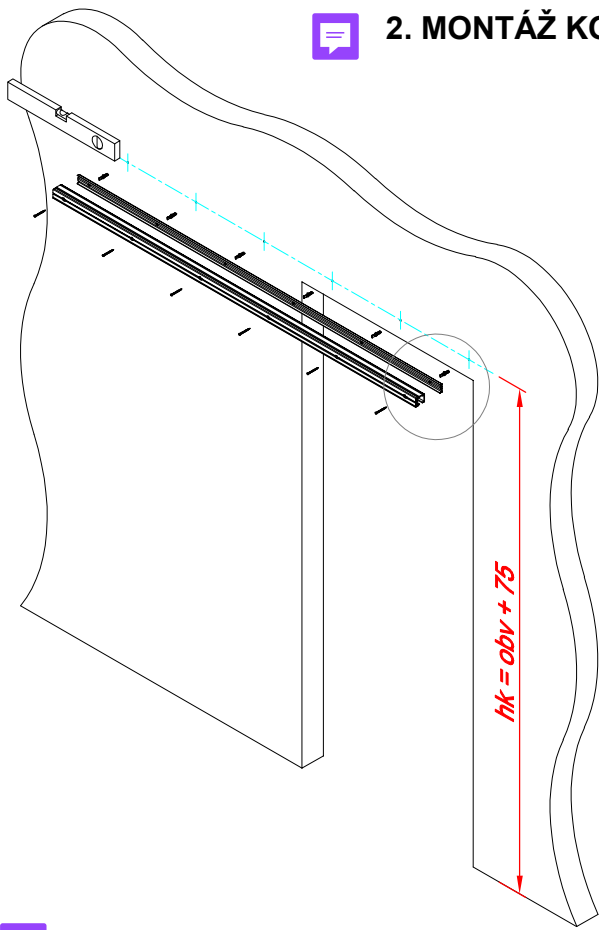

hk - výška osy vrtání kolejnice
 oby - objednáací výška
 pk - přesah kolejnice přes svislou hranu stavebního otvoru



bez bočního dorazu (A, E) pk = 25 mm
 s bočním dorazem (C, G) pk = 75 mm



3. MONTÁŽ NOSNÉ LIŠTY DORAZU A BOČNÍHO DORAZU - bez zárubně (C, G)

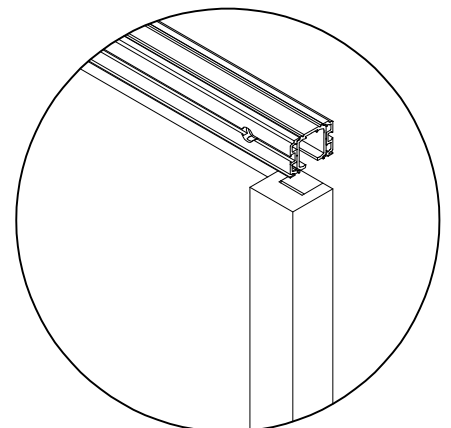
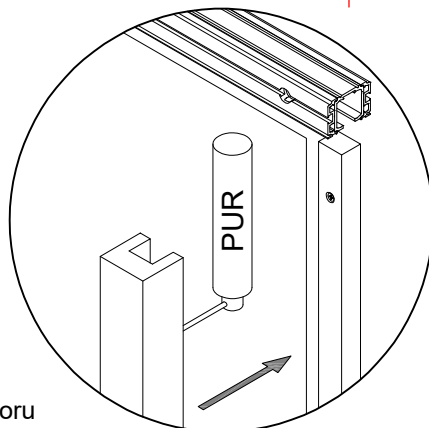
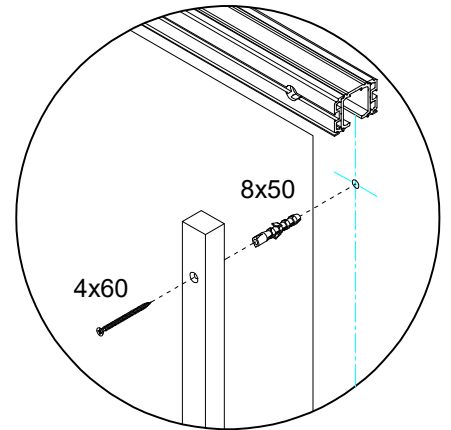
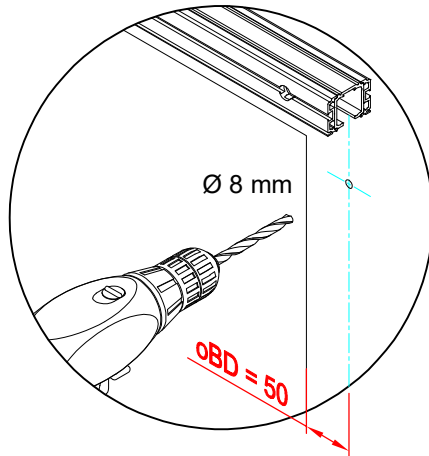
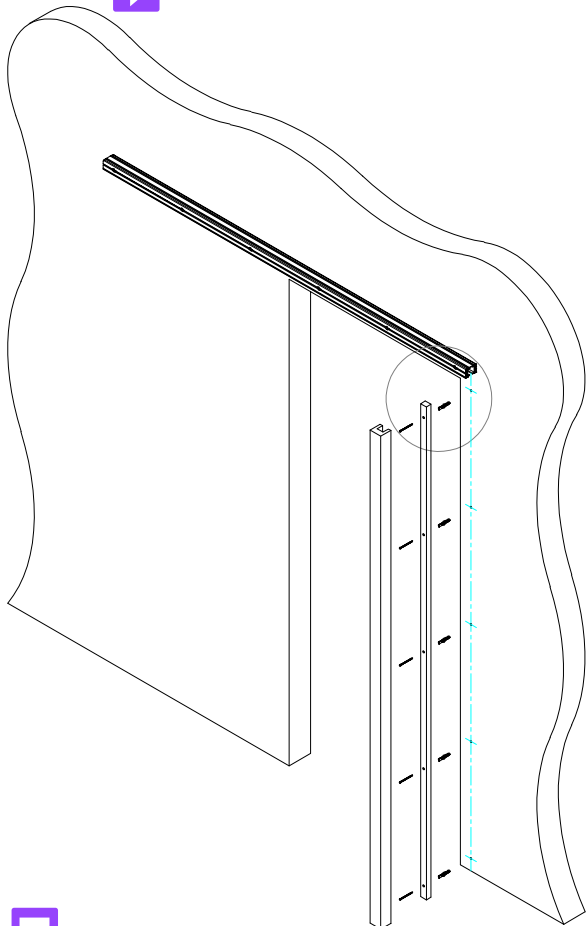

oBD - osa vrtání pro boční doraz od svislé hrany otvoru



4. MONTÁŽ BOČNÍHO DORAZU - se zárubní (D, H)

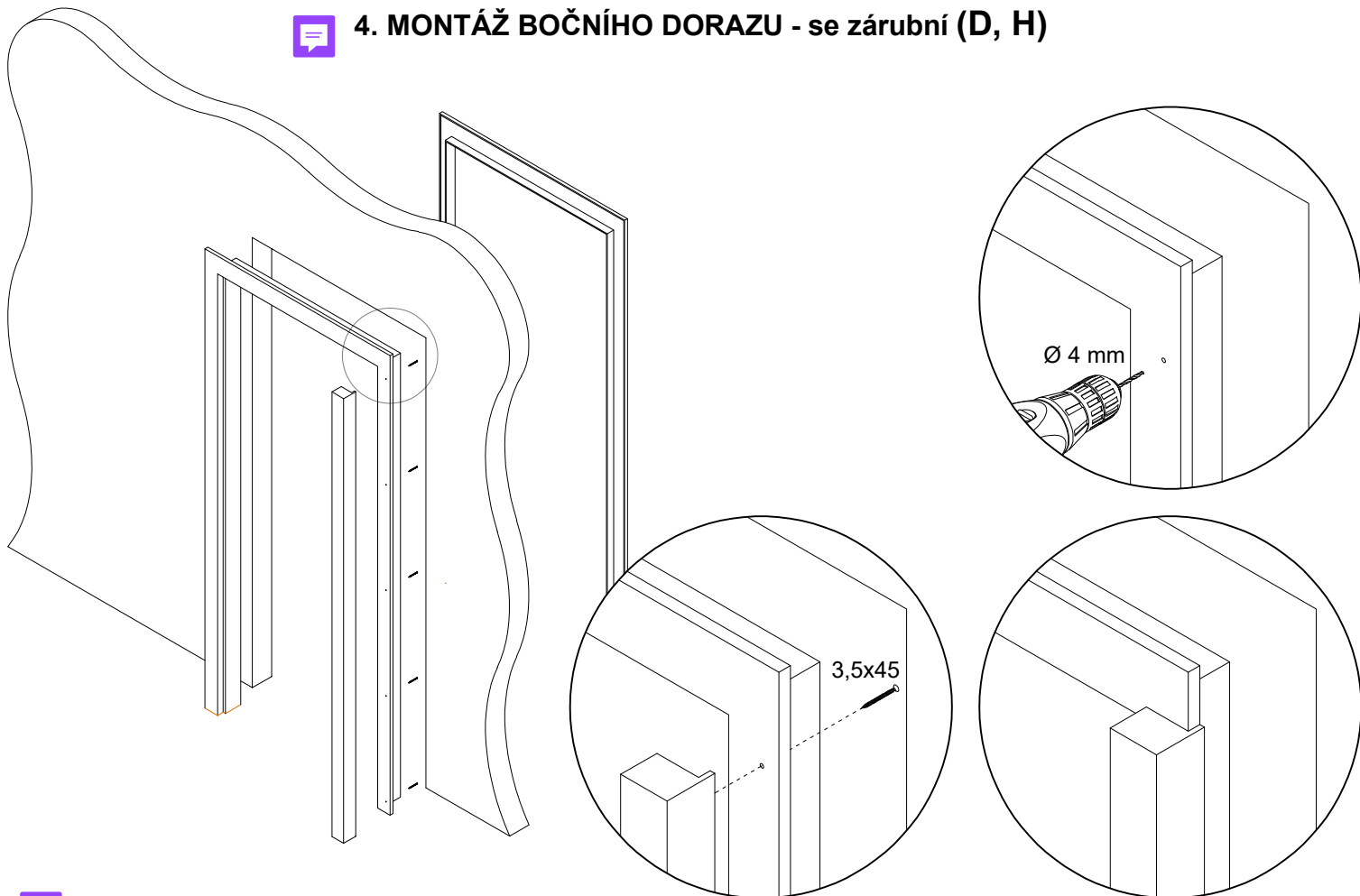

* Montáž zárubně do stavebního otvoru se provádí dle samostatného návodu.



5. MONTÁŽ DISTANČNÍ LIŠTY - se zárubní (B, D, F, H)

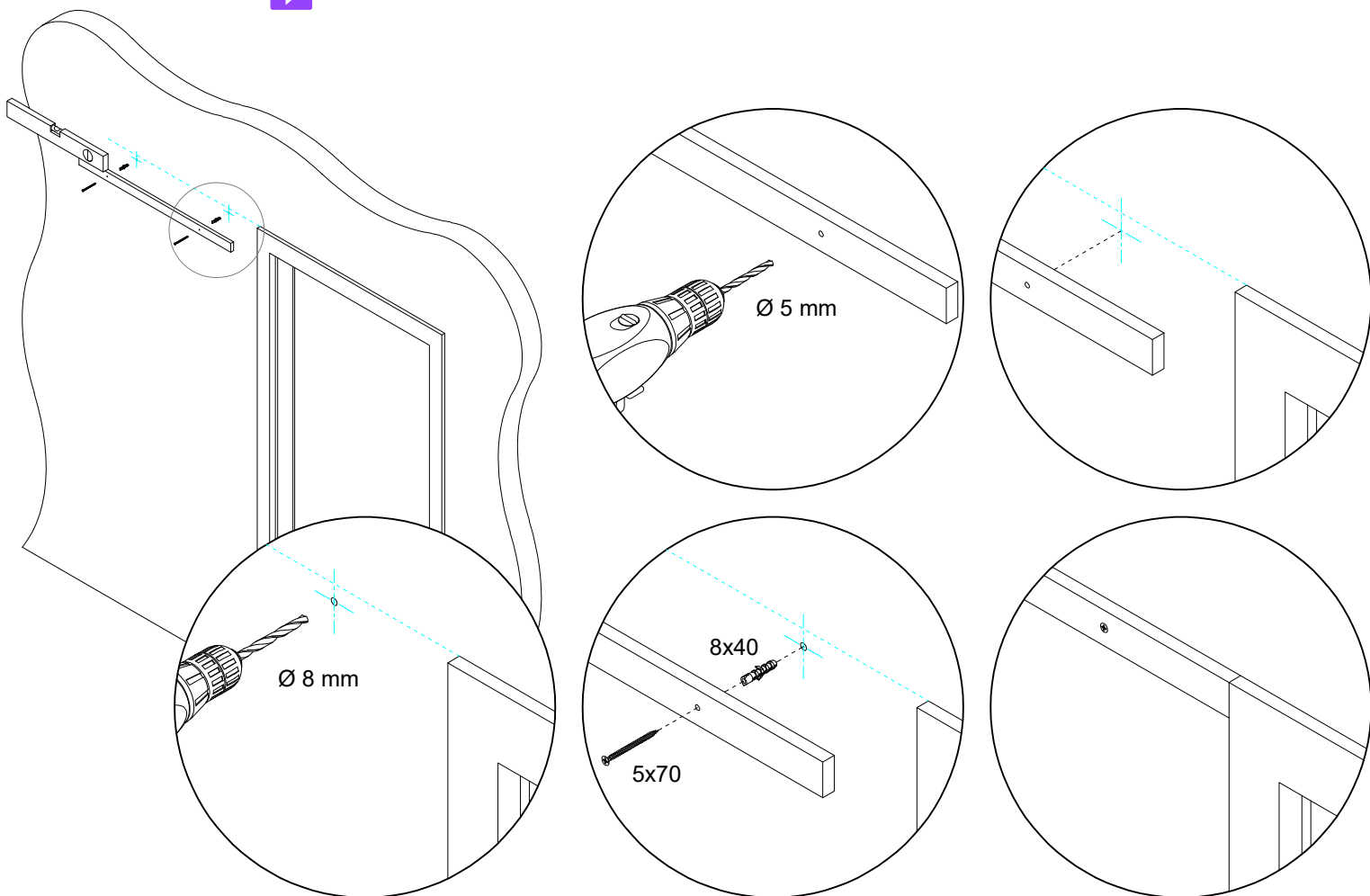

6. MONTÁŽ KOLEJNICE - se zárubní (B, D, F, H)

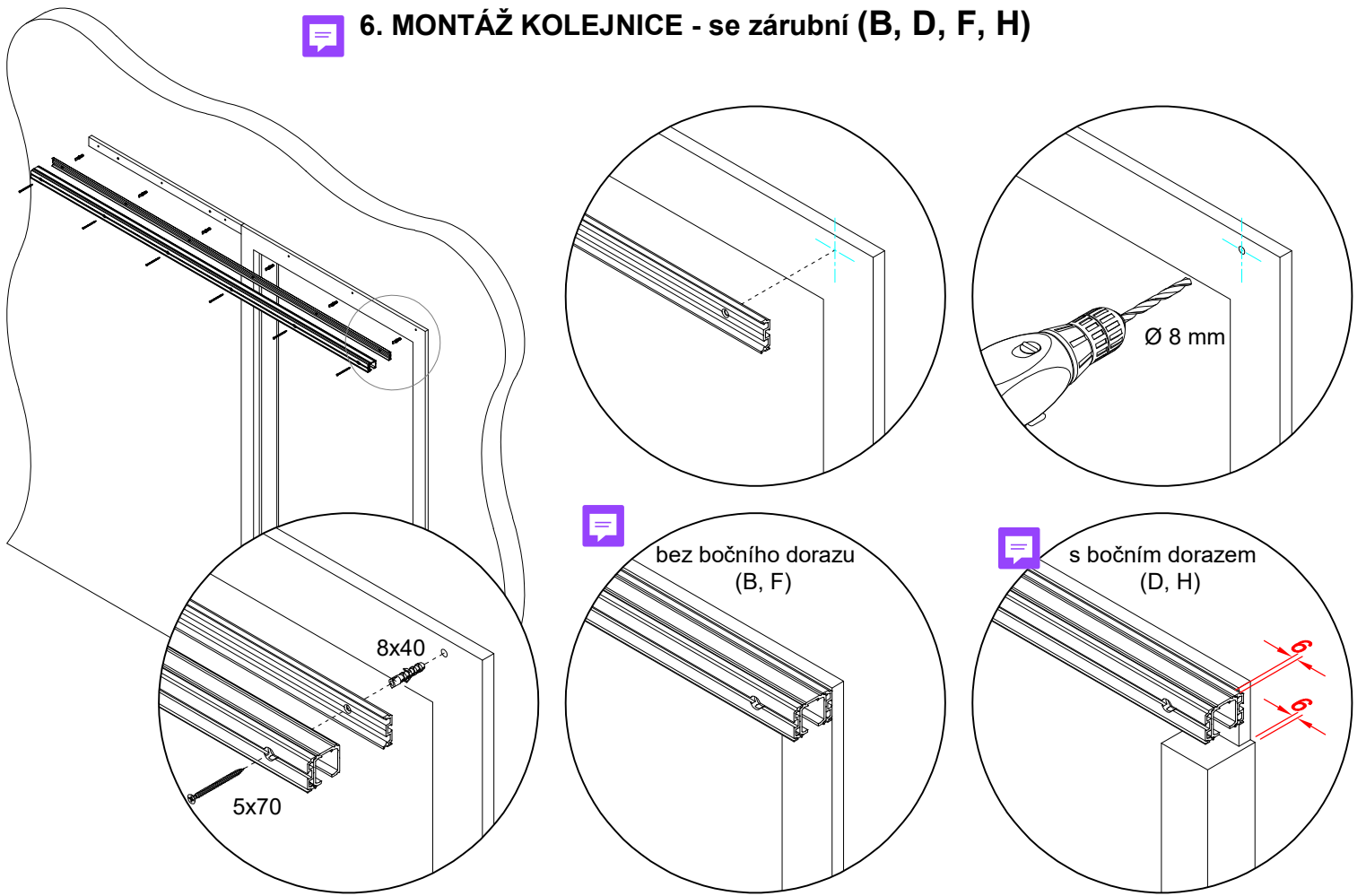

7. PŘÍPRAVA SOFTOVÉHO TLUMIČE (A, B, C, D, E, F, G, H)

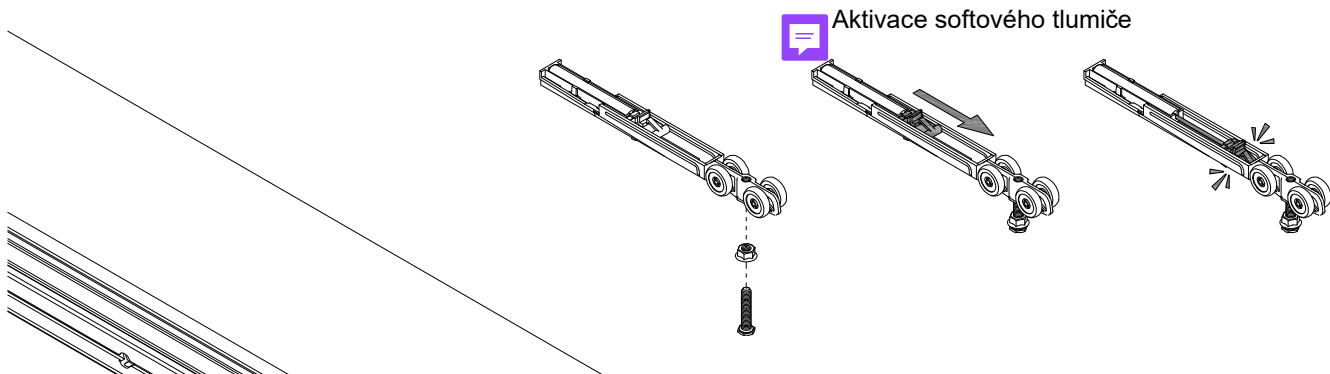

8. VSUNUTÍ SOFTOVÝCH TLUMIČŮ A AKTIVÁTORŮ DO KOLEJNICE (A, B, C, D, E, F, G, H)

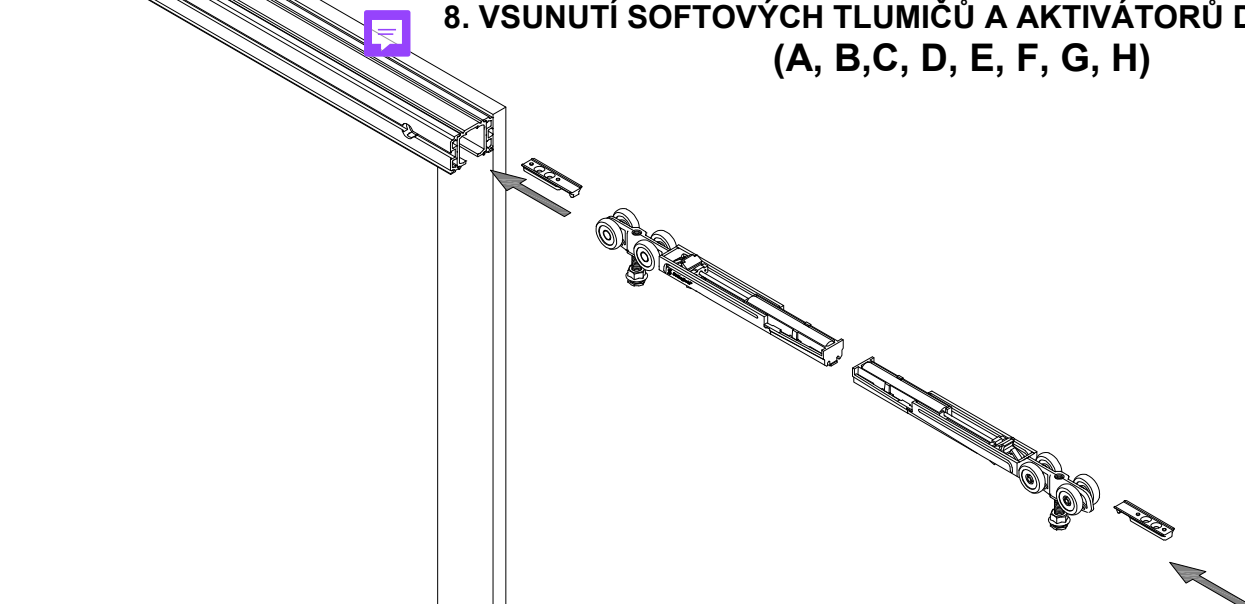

9. OSAZENÍ DRŽÁKŮ DVEŘÍ (A, B, C, D, E, F, G, H)

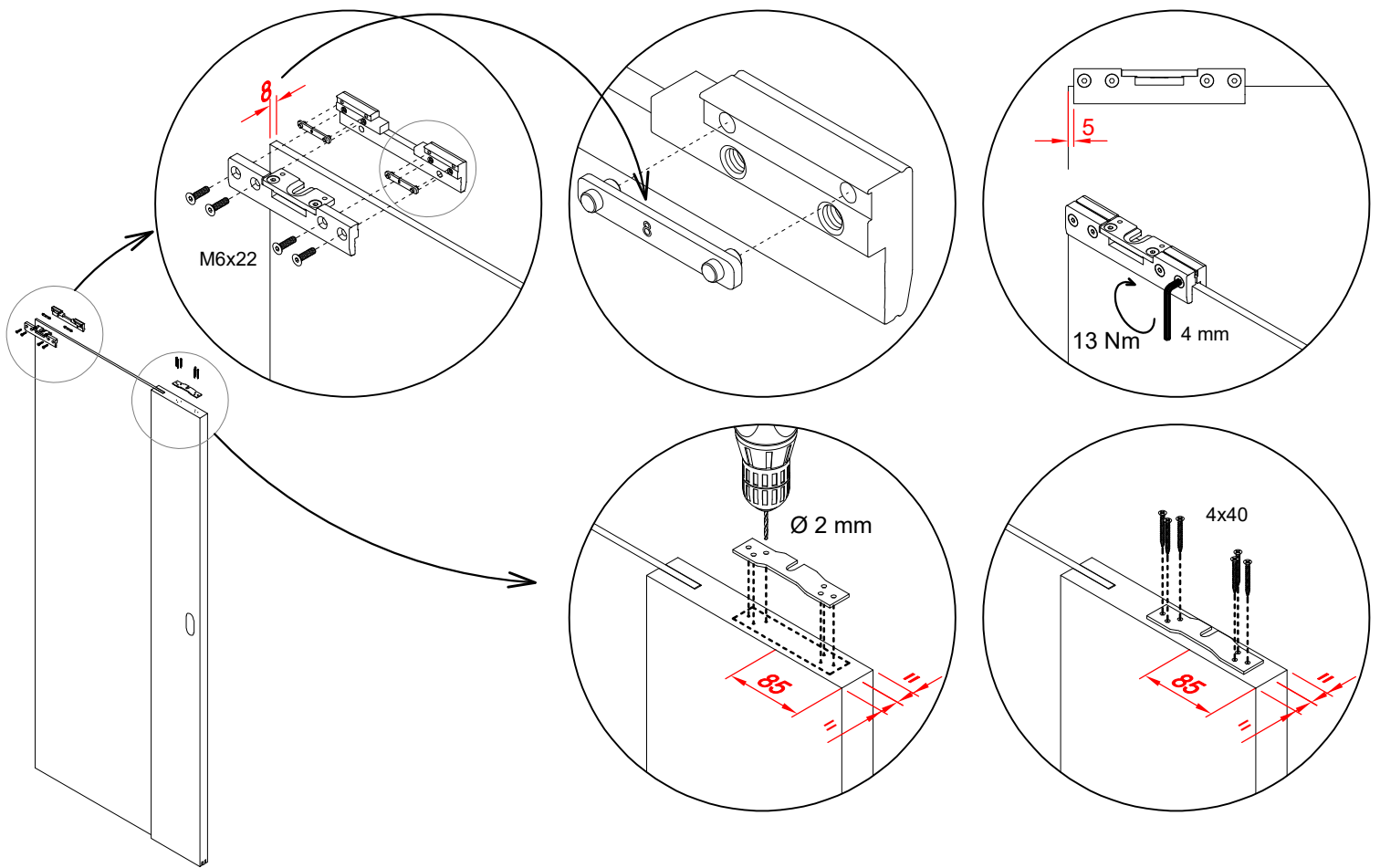

10. NAsAZENÍ KŘÍDLA NA VOZÍČKY (A, B, C, D, E, F, G, H)

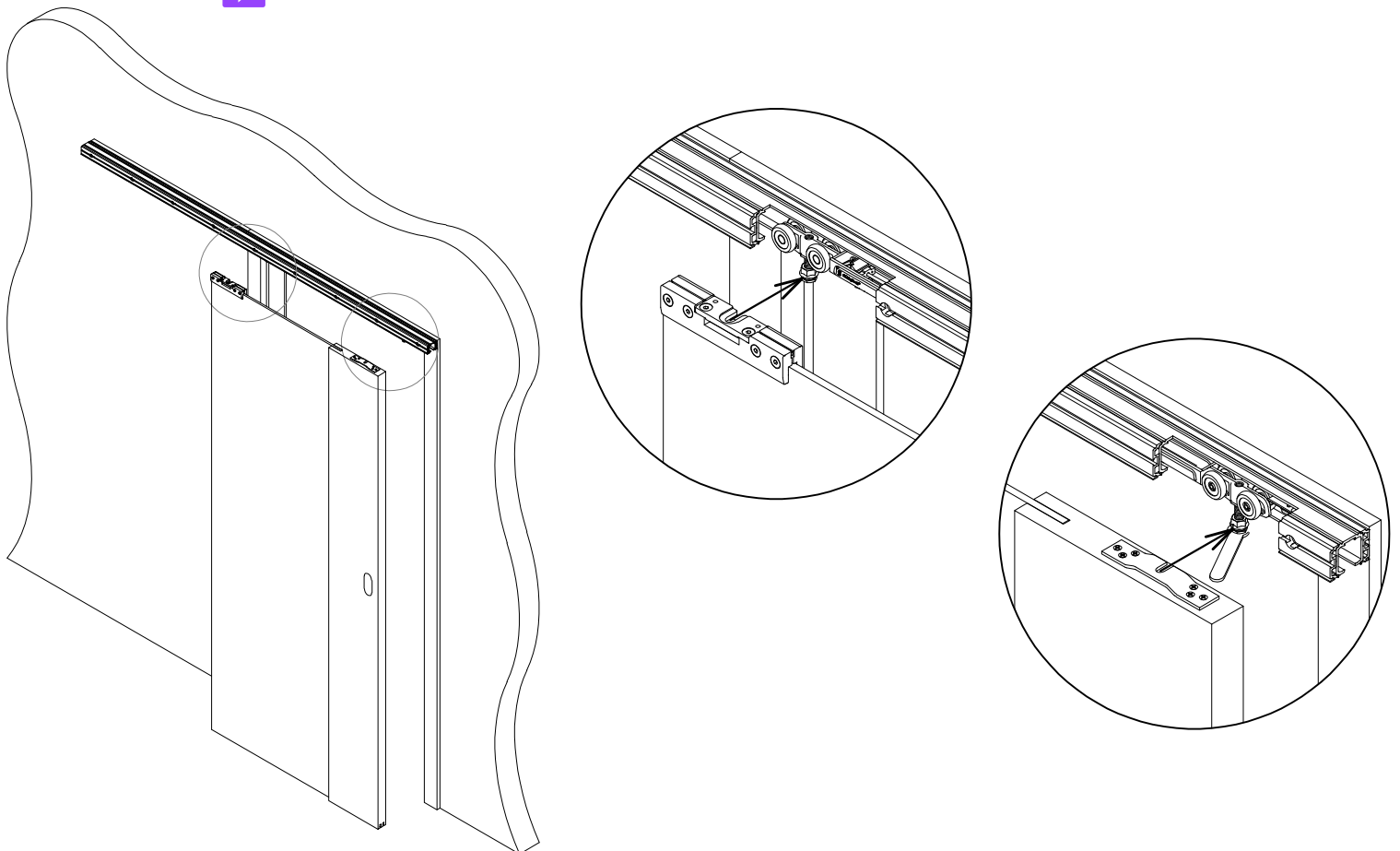

11. VÝŠKOVÁ REGULACE, VYVÁŽENÍ A ZAJIŠTĚNÍ KŘÍDLA (A, B, C, D, E, F, G, H)

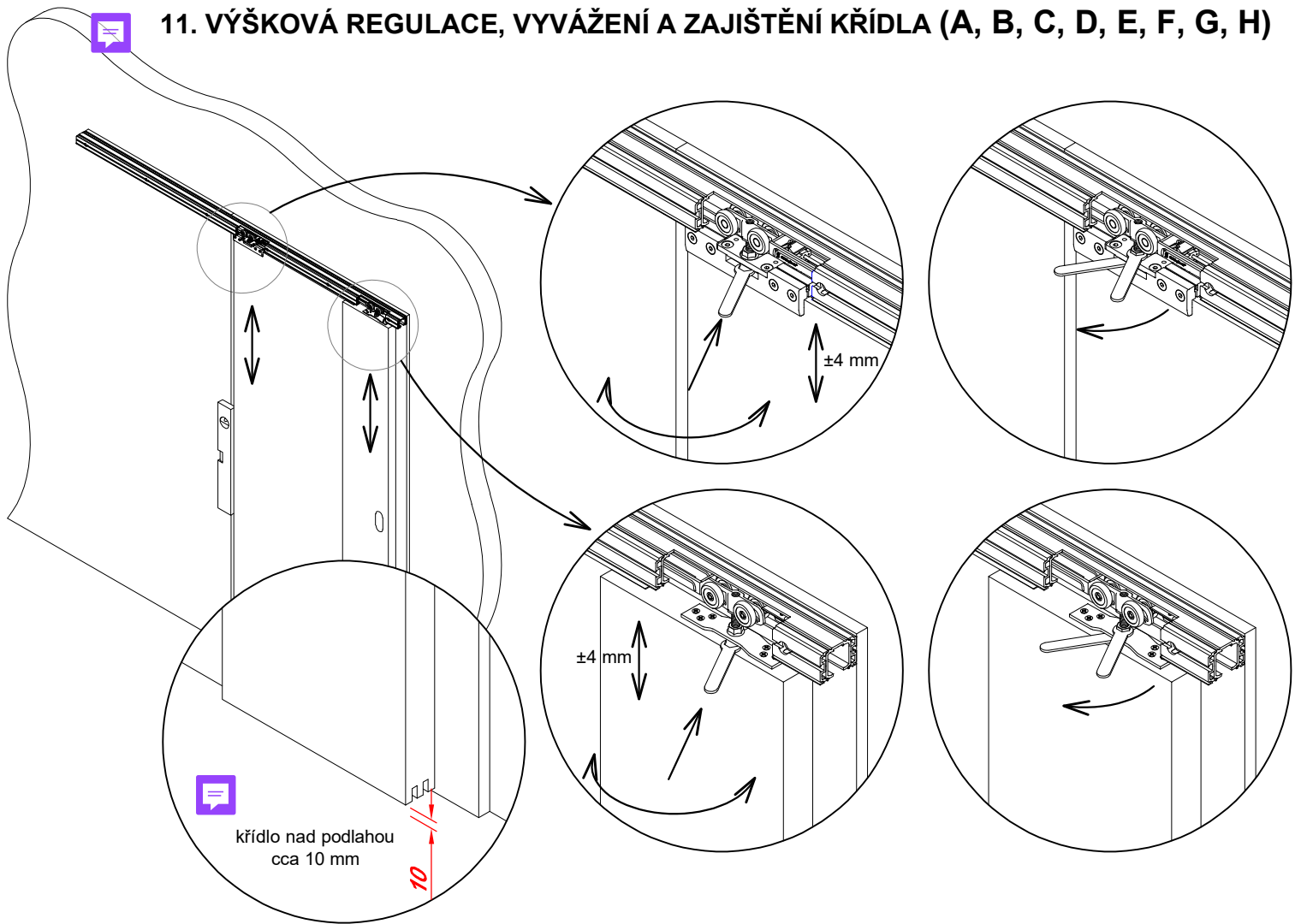

12. MONTÁŽ VODÍTKA (A, B, C, D, E, F, G, H)

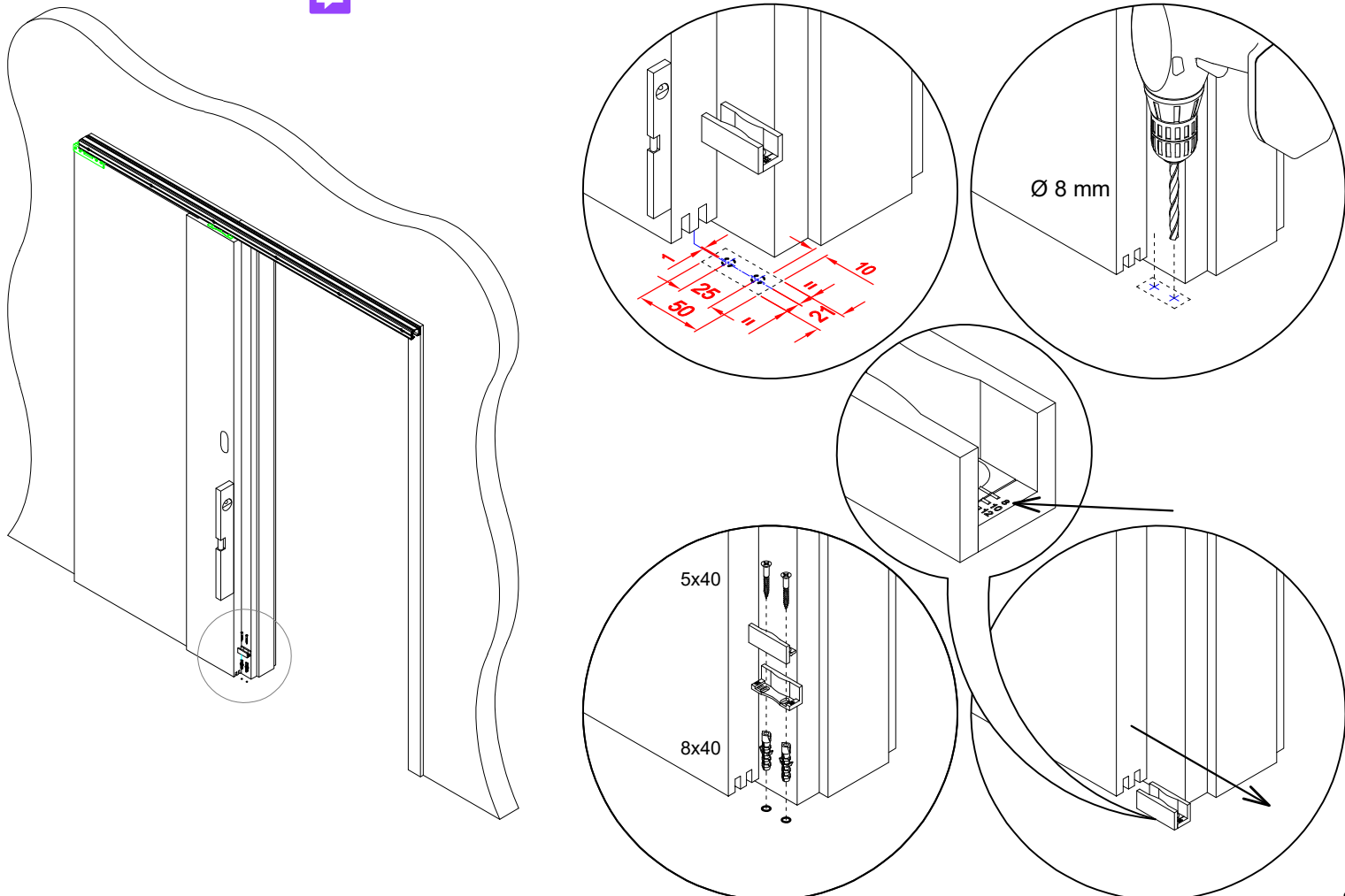

13. NASTAVENÍ AKTIVÁTORU V POLOZE ZAVŘENO (A, B, C, D, E, F, G, H)

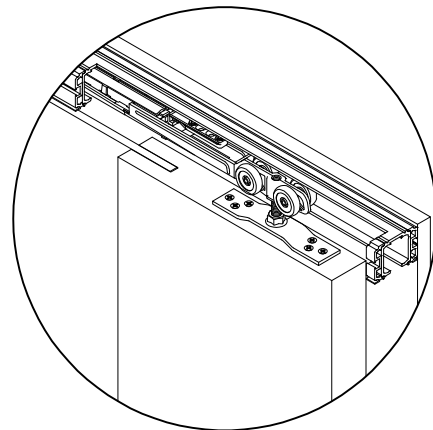
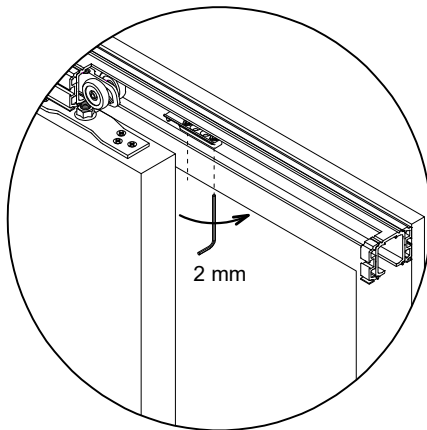
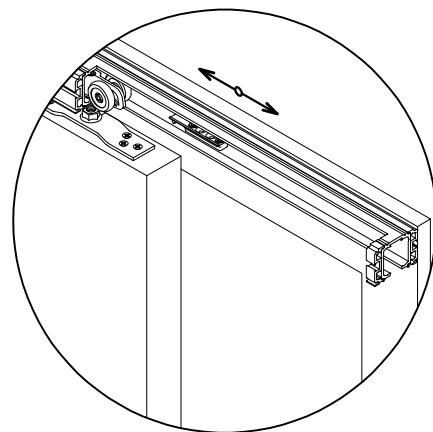
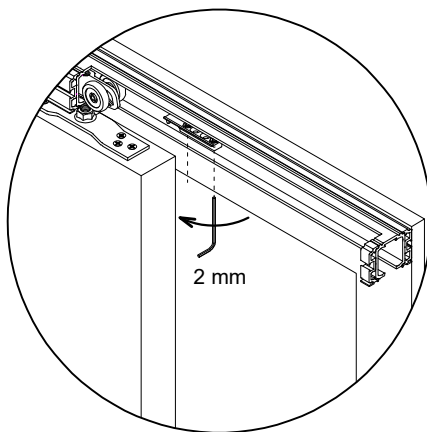
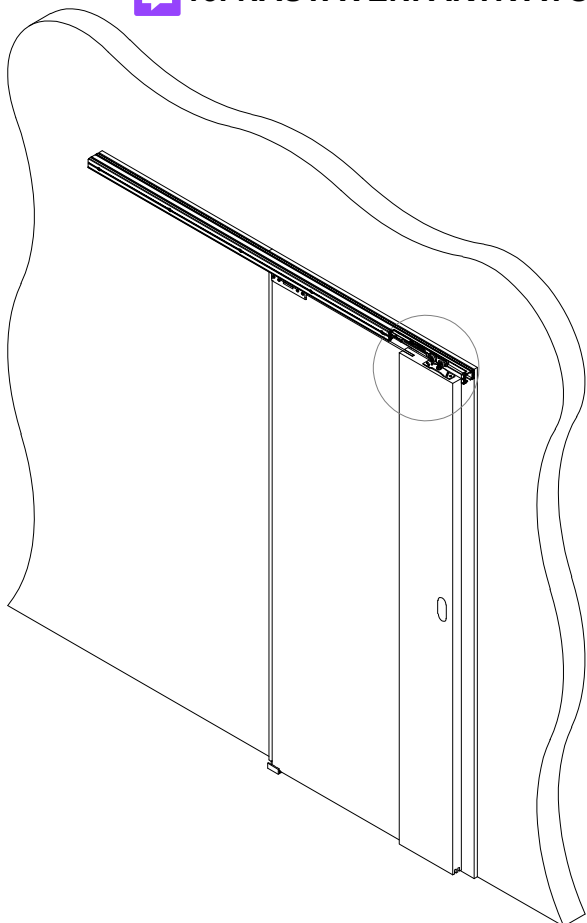

14. NASTAVENÍ AKTIVÁTORU V POLOZE OTEVŘENO (A, B, C, D, E, F, G, H)

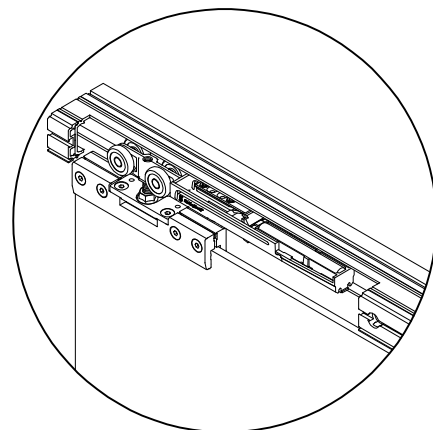
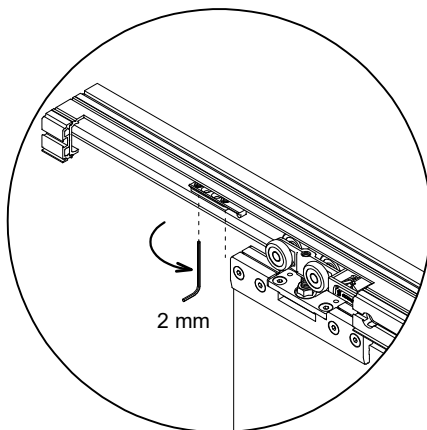
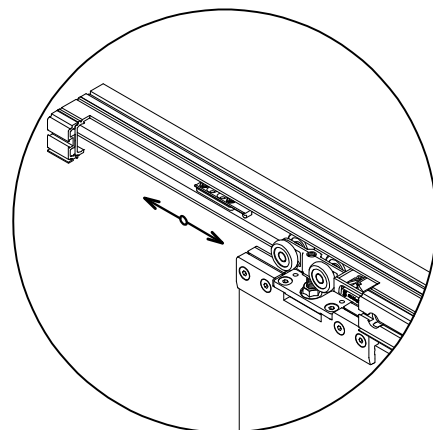
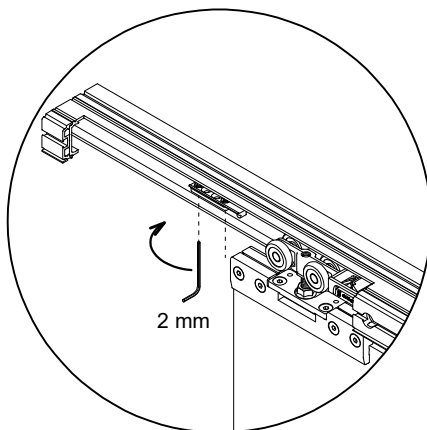
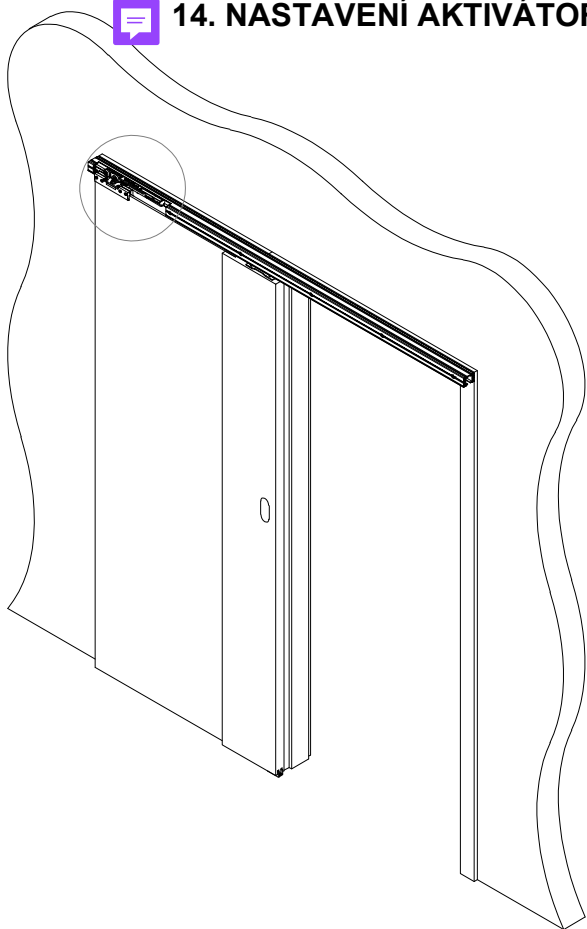

 15. NAsAZENÍ DŘEVĚNÉ GARNÝŽE (E, F, G, H)

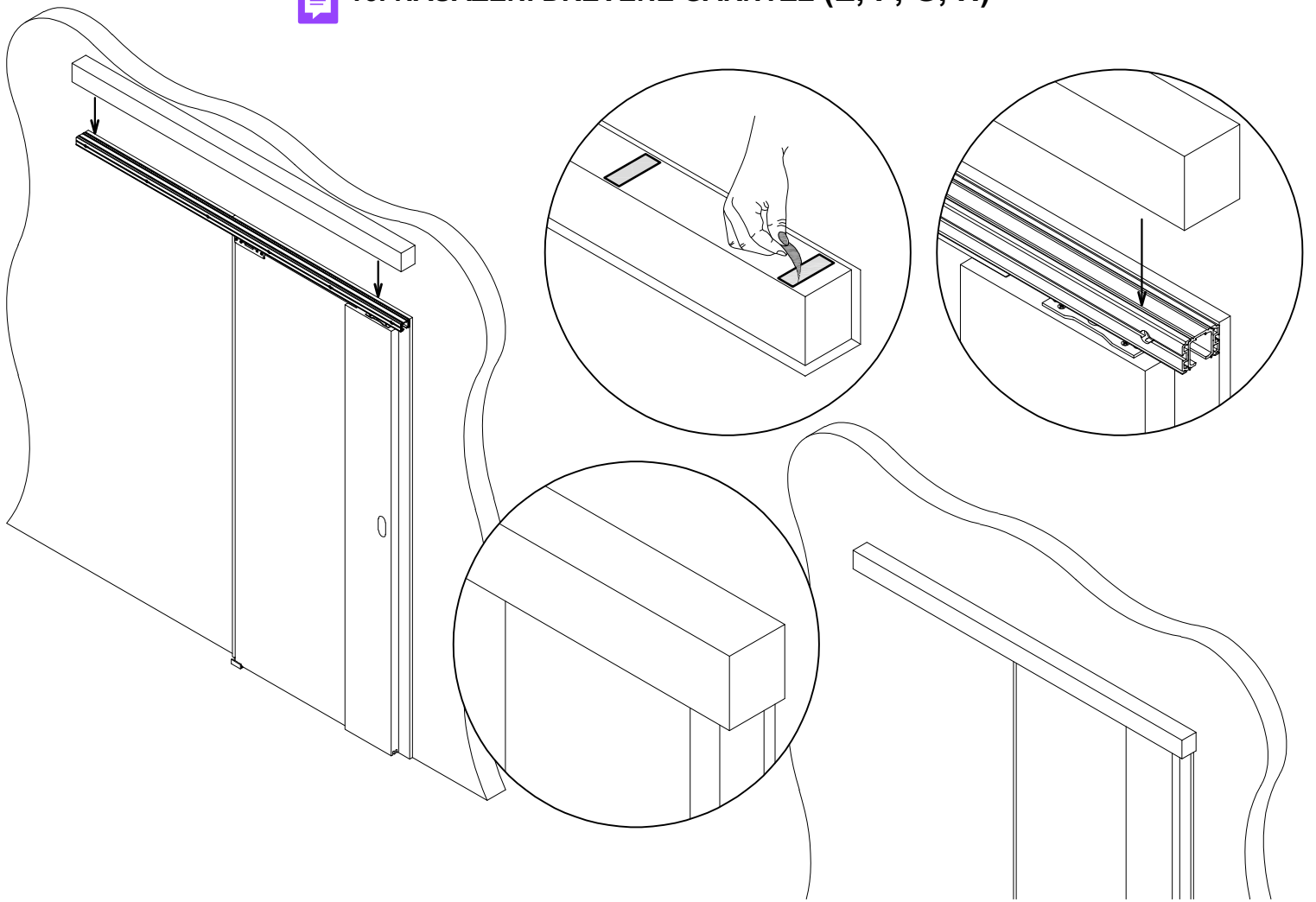

 16. VSUNUTÍ DRŽÁKU BOČNÍ KRYTKY (A, B, C, D)

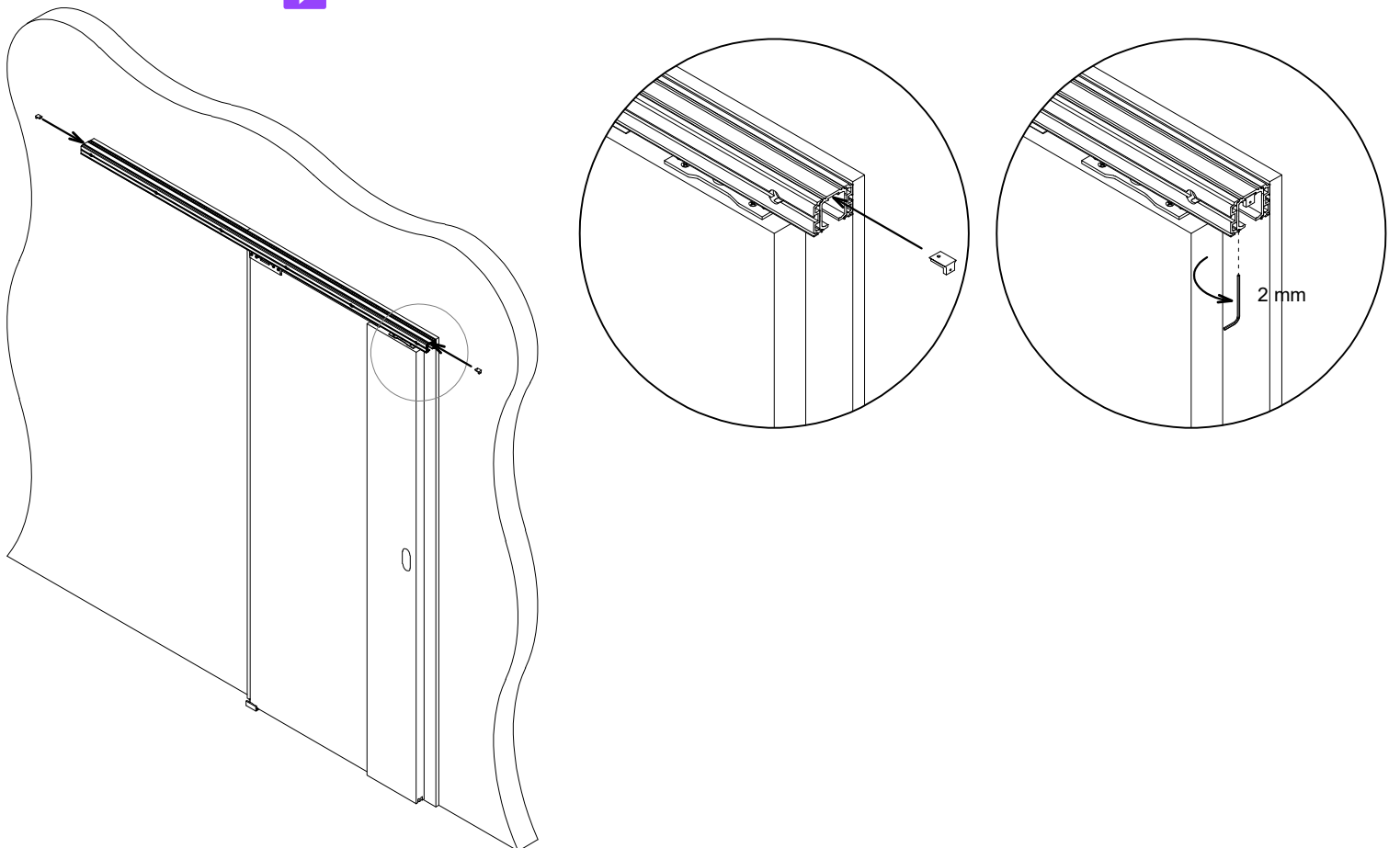



17. NAsAZENÍ ČELA AL GARNÝŽE (A, B, C, D)

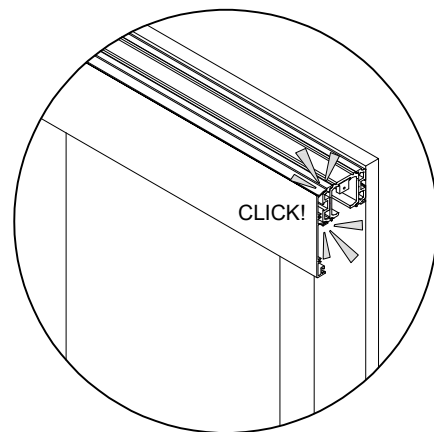
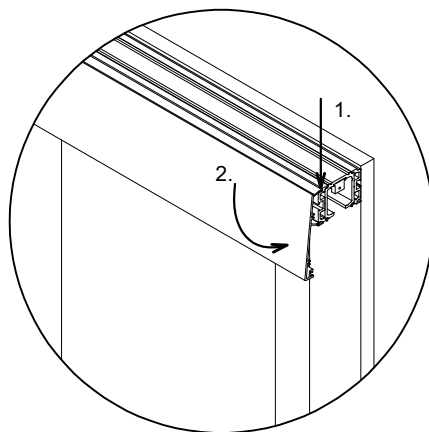
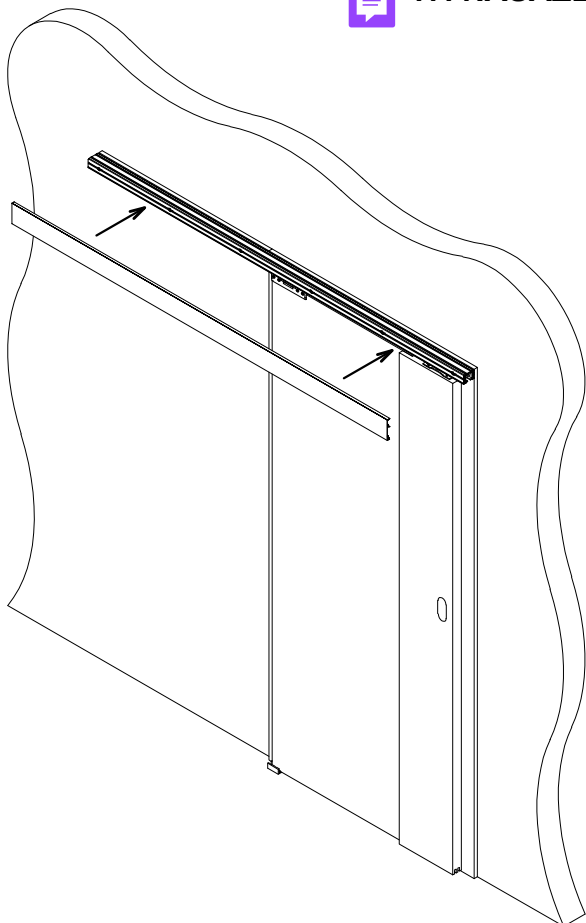

18. NAsAZENÍ BOČNÍ KRYTKY AL GARNÝŽE (A, B, C, D)

